

PIPE SYSTEMS
MADE IN
GERMANY



Mainair

Residential Ventilation System



THE TECHNICAL MANUAL

Mainair

Residential Ventilation System

All legal and technical information has been carefully compiled to the best of our knowledge. No liability can be accepted for any errors or omissions. This document including the contents is protected by copyright. Any use prohibited by copyright is not allowed without the permission of MAINCOR Rohrsysteme GmbH & Co. KG. All rights reserved. In particular reprinting, editing, storage and processing in electronic systems, translations and microfilms. Subject to printing errors and technical changes. All previous versions lose their validity. Please consider legal provisions, technical regulations, approvals and standards.

1. Warranties	4
2. Planning and installation information	5
2.1 Basic terms according to DIN 1946-6	5
2.2 Operation of fireplaces & ventilation systems/units	8
2.3 Statement - The Federal Association of the Chimney Sweeping Trade	9
2.4 Overview of filter classes	11
2.5 MAINAIR measurement protocol	12
2.6 MAINAIR commissioning protocol	13
2.7 Installing system components	15
3. MAINAIR & MAINSILVER ventilation pipes	16
4. Ventilation connection and distribution channels	18
5. Distribution boxes	21
6. Accessories	25
6.1 Supply and exhaust valve positioning	27
7. Ventilation unit	33



ONLINE-QUICK-CALCULATION

- No time-consuming software installation
- Quick & easy calculation
- Direct ordering
- Download PDF quotation



1. Warranties



CERTIFICATE

MAINAIR Ventilation pipe

Our MAINAIR as well as our MAINSILVER ventilation pipe in dimensions 63 (outer diameter: 63 mm x wall thickness: 6.3 mm), 75 (outer diameter: 75 mm x wall thickness: 7 mm) and 90 (outer diameter: 90 mm x wall thickness: 7,5 mm) is compatible with all common ventilation systems in the given dimensions.

ANTIBACTERIAL

We herewith confirm that our MAINSILVER ventilation pipe has an antibacterial activity against the germs *staphylococcus aureus* ATCC 6538P and *escherichia coli* ATCC 8739 according to ISO 22196:2011-08 „Measurement of antibacterial activity on plastics and other non-porous surfaces“. The test was carried out by an official test institute.

RAW MATERIAL POLYETHYLEN (PE)

Our ventilation pipes are made exclusively from new material. Thus, no unwanted odors develop.

HYGIENE

We herewith confirm the suitability of our ventilation pipes for use in residential ventilation systems. All our pipes have been tested by an official test institute based on DIN EN ISO 846 „Evaluation of the action of microorganisms on plastics“.

ANTISTATIC

Since surfaces with a resistance of $\leq 10^{12} \Omega$ have an antistatic effect, the inner pipe layer of our ventilation pipes has such an antistatic finish/effect.

In the event of a complaint, MAINCOR will determine the cause of the error and assume the warranty if the individual components are installed professionally.

The statutory warranty obligations of the respective manufacturer for the products he puts into circulation, remain in place.

Schweinfurt, December 1, 2025

Dieter Pfister
Managing director

2. Planning and installation information

2.1 Basic terms according to DIN 1946-6

Exhaust air space

Total of the rooms from which exhaust air flows when using shaft- and fan-supported ventilation: e.g. kitchen, bathroom, toilet, shower, utility room, sauna and unoccupied basement rooms

Exhaust air system

Central fan ventilation system or domestic ventilation unit with fan-supported exhaust air, with the supply air flowing as untreated outside air into the utilisation units via outside air passage or leaks in the building exterior

Living area

Area in rooms designed for the permanent presence of people, formed by a height of 0.1 m to 1.8 m above the floor and a distance of 0.5 m from the external and internal walls and 1.0 m from the external windows, doors and radiators

Updraft ventilation

Form of free ventilation where the main driving force is thermal updraft.

Even ventilation

Fan-assisted ventilation, in which the supply air and exhaust air flow rates have the same rated value (also "balanced ventilation")

Demand ventilation

Fan-assisted ventilation with air flow rates (e.g. sensor technology) adapted to the respective demand.

Rated differential pressure

Planned difference in total pressures between the air inlets and outlets of units or via air vents, e.g. outside air passage and overflow air passage.

(Air) tightness

Description of the state of the exterior structure with regard to its (air) permeability; synonym for the lowest possible permeability; antonym: leakiness

(Air) permeability

Volumetric air flow rate which, at a given differential pressure, flows into or out of a utilisation unit via air passages and via leaks in the building exterior.

Free ventilation device

Opening windows, external wall air passage, ventilation shaft and specifically designed (functional) joints of windows and external doors

Single fan ventilation system

Exhaust air system with individual fans for multi-family or detached houses.

Waste air passage

Device in ventilation shafts and main or individual ventilation pipes from which the air flows outside in a controlled or uncontrolled manner.

Total outside air flow rate

The total effective air flow rate in the utilisation unit in the utilisation phase, which results from planned free or fan-assisted ventilation as well as unplanned infiltration and window ventilation.

Equivalent diameter

Diameter of a straight ventilation pipe of rectangular cross-section which results in the same pressure drop as a circular ventilation pipe at the same air flow rate.

Air heater

Device for transferring thermal energy from a transfer (heating) medium to a piped air mass flow.

Air routing

Target air flow in a room with fan-assisted ventilation

Air mass flow rate

Air mass per unit of time

Air temperature gradient

Vertical air temperature difference per m, measured between 1.1 m and 0.1 m above the floor

(Volumetric) air flow rate

Air volume per unit of time

Air change

Hourly volumetric air flow rate, based on the volume of a utilisation unit or a room.

Minimum ventilation

User-independent ventilation that meets minimum indoor air quality requirements under normal conditions of use (moisture and pollutant loads).

(Dwelling) utilisation unit

Flat, detached house or other similar group of rooms

Overflow spaces

Rooms in the utilisation unit located between the supply air and exhaust air spaces in terms of flow.

(Converted) room

Section of a utilisation unit enclosed by the building envelope

Collecting conduit

Umbrella term for the main pipe and the collective/connecting shaft, each with a vertical arrangement or a horizontally arranged connecting pipe for main pipes.

Single fan

Fan inside the utilisation unit for extracting exhaust air from a room

Central fan

Fan located outside the utilisation unit for conveying exhaust air or supply air from or into several utilisation units or rooms within a single utilisation unit.

Degree of heat supply

Ratio of the enthalpy provided for use by the ventilation unit to the enthalpy differential of the two fluid flows of equal mass when entering a unit, including increases, e.g., by a heat pump, and reductions, e.g., by a frost protection/defrosting device.

Ground-to-air heat exchanger

Device for transferring thermal energy from the ground to a piped air mass flow (in case of heating) or vice versa (in case of cooling).

Wind ventilation

Form of free ventilation where the main driving force is the wind.

Dwelling

The total of the rooms for the running of a household, whether a flat or maisonette or a single-family house (a detached, semi-detached or terraced house), also a housing unit.

Central fan ventilation system

Exhaust air or supply and exhaust air system with central fan for multi-family or detached houses.

Central ventilation unit

Location for the central installation of exhaust air or supply-and-exhaust air fans, including the components for heat recovery and outside air filtration of the supply/exhaust air system of a central fan ventilation system or domestic ventilation unit with treated supply and exhaust air delivered with fan support.

Supply air spaces

All rooms into which thermally untreated outside air flows in via shaft ventilation and exhaust air systems, and into which treated supply air is led via supply and exhaust air systems: e.g. living rooms, bedrooms, guest rooms, utility rooms and children's rooms as well as permanently or temporarily used hobby rooms, attics and cellars.

2.2 Operation of fireplaces & ventilation systems/units

According to DIN 1946-6 (Chapter 8), ventilation systems must not impair the proper operation of fireplaces. For this purpose, the requirements of the state combustion ordinances apply regarding the installation and the supply of combustion air. A basic distinction is made between "open flue" and "balanced flue" fireplaces.

Balanced flue fireplaces

Balanced flue fireplaces, to which the combustion air is supplied from the outside via pipes or shafts, and where no exhaust gas can escape into the installation space in a potentially hazardous volume, are suitable for joint operation with ventilation systems without further measures. Usage advice is essential, e.g. a general approval by the building supervisory authorities.

Open flue fireplaces

When using a ventilation system with an open flue fireplace, safety devices are required! When the ventilation system is operated in combination with a fireplace, you have various options, such as pressure differential boxes. Install a pressure monitor on the supply air fan or in the supply ventilation pipe. The power supply to the exhaust air fan is only enabled when the supply air fan delivers air.

Electrical fuse. The exhaust air fan is switched OFF when the supply air fan is at rest. Proper functioning of the safety device must be verified and documented during commissioning. Once again, usage advice is essential, e.g. a general approval by the building supervisory authorities.

Our recommendation

In order to avoid subsequent discussions, we recommend contacting the responsible master chimneysweep for the district as early as the planning phase.

See also the official statement of the "Federal Association of the Chimney Sweeping Trade"



2.3 Statement - The Federal Association of the Chimney Sweeping Trade

ASSESSMENT CRITERIA FOR THE JOINT OPERATION OF FIREPLACES - DOMESTIC VENTILATION - EXTRACTOR HOODS

The following assessment criteria shall apply until the publication of appropriate regulations

System:

Fireplace: open flue

Domestic ventilation system: central, supply and exhaust air, heat recovery, extractor hood

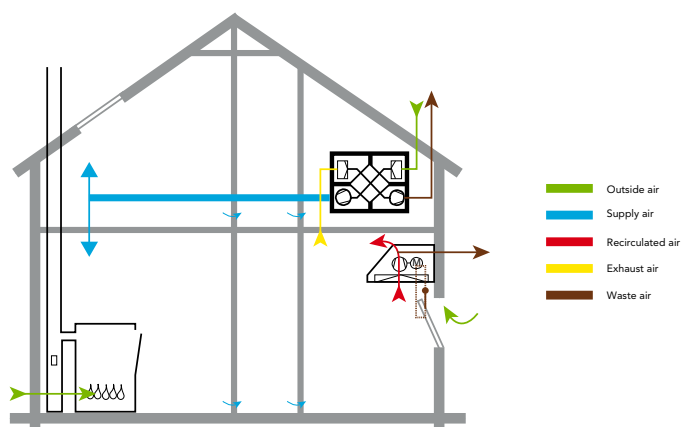

Measures to be followed:

Open flue fireplaces

Separate combustion air supply into the combustion chamber. Cross-section according to the manufacturer of the fireplace. Single lined chimney or air/exhaust gas chimney. Make the connecting piece as tight as possible.

Domestic ventilation system

Frost protection for the ventilation unit must not be accomplished by shutting down the supply air fan, but rather by:

- preheating the outside air with an electric or water heating coil
- a ground pipe heat exchanger
- or equivalent measures

The exhaust air fan switches off automatically if the supply air fan malfunctions.

Extractor hoods

Are to be operated in recirculation mode. Can also be operated in waste air mode, if no greater vacuum than 4 Pa is created due to an adequate volume of supply air at the max. flow rate of the extractor hood. This is considered to be fulfilled if the window opening is sufficiently large, or the supply air device is dimensioned appropriately and the extractor hood is activated by a contact switch, or if there is a sufficiently dimensioned supply air fan electrically coupled to the extractor hood, or if the extractor hood is switched off by an external fault message (e.g. response of a vacuum monitor at the fireplace)

An initiative of the Association for Domestic Ventilation in cooperation with the Federal Association of the Chimney Sweeping Trade and:



**Federal Association of the Chimney Sweeping Trade
- Central Guild Association (ZIV) -**

Westerwaldstraße 6
53757 Sankt Augustin, Germany
Phone: +49 (02241) 34070
www.schornsteinfeger.de



Bau und Betrieb (Construction and Operation)

Ridlerstraße 65
80339 Munich, Germany
Phone: +49 (089) 51901018
www.tuev-sued.de



**Industrieverband Haus-, Heiz- und Küchentechnik e.V.
(Industry Association for Home, Heating and Kitchen
Technology)**

Stresemannallee 19
60596 Frankfurt am Main, Germany
Phone: +49 (069) 2562680
www.hki-online.de



**Bundesverband der Firmen im Gas und Wasserfach e. V.
(Federal Association of Companies in the Gas and Water
Industry)**

Marienburger Strasse 15
50968 Cologne, Germany
Phone: +49 (0221) 3764830
www.figawa.de



**Verband für Wohnungslüftung e. V. (Association for
Residential Ventilation)**

Wittinger Strasse 46
29223 Celle, Germany
Phone: +49 (05141) 214511
www.wohnungslueftung-ev.de

2.4 Overview of filter classes

Particle size	Particle examples	Filter class	Application examples	
Coarse dust particle filter > 10 µm	<ul style="list-style-type: none"> - Insects - Textile fibres and hair - Sand - Fly ash - Flower dust - Spores, pollen - Cement dust 	G 1	- For simple applications (e.g. as insect protection in compact units)	
		G 2		
Particulate filter 1 – 10 µm	<ul style="list-style-type: none"> - Flower dust - Spores, pollen - Cement dust - Particles that cause stains and dust deposits, bacteria and germs on host particles 	G 3	<ul style="list-style-type: none"> - Pre- and recirculating air filters for civil protection systems - Exhaust air from paint spray booths and kitchen exhaust air, etc. - Contamination protection for air conditioning units and compact units (e.g. window air conditioning units, fans) - Pre-filter for filter classes F 6 to F 8 	
		G 4		
		F 5		<ul style="list-style-type: none"> - Outside air filter for rooms with low requirements (e.g. workshops, storage rooms, garages)
		F 5 F 6 F 7		

Size-based fractional separation rates for filter classes G 1 to F 9 according to DIN EN 779. Filter in undusted, clean state.

Separation efficiency in %							
Filter class	Particle size (µm)						
	0.1	0.3	0.5	1	3	5	10
G1	-	-	-	-	0-5	5-15	40-50
G2	-	-	-	0-5	5-15	15-35	50-70
G3	-	-	0-5	5-15	15-35	35-70	70-85
G4	-	0-5	5-15	15-35	30-55	60-90	85-98
F5	0-10	5-15	15-30	30-50	70-90	90-99	>98
F6	5-15	45-60	20-40	50-65	85-95	95-99	>99
F7	25-35	45-60	60-75	85-95	>98	>99	>99
F8	35-45	65-75	80-90	95-98	>99	>99	>99
F9	45-60	75-85	90-95	>98	>99	>99	>99

Note:

This table provides reference values for the different filter classes.

Specific values for different filter types must be measured taking into account the inflow velocity of interest.

2.5 MAINAIR measurement protocol

MAINAIR measurement protocol (appendix for commissioning)		Building project		
Operator _____		Volume settings according to E DIN 1946-6		
		Minimum ventilation=	stage 1=	m ³ /h
		Basic ventilation=	stage 2=	m ³ /h
		Intensive ventilation=	stage 3=	m ³ /h
1. Air flow settings				
2. Air volume set according to the design of the central unit?		yes	no	
3. Valve set according to volume calculation		yes	no	
4. Valve set with measuring instrument:		yes	no	
Type: _____				
Observe calibration				
Measured values				
Supply air spaces	Floor	Actual value in m ³ /h	Target value in m ³ /h	OK
Living				set
Eating				set
Child 1				set
Child 2				set
Sleeping				set
Office				set
Guest room				set
				set
				set
				set
				set
				set
				set
Exhaust air spaces	Floor	Actual value in m ³ /h	Target value in m ³ /h	OK
Kitchen (with filter)				set
Toilet				set
Bath				set
Storeroom				set
				set
				set
				set
				set
				set
				set
				set
				set

2.6 MAINAIR commissioning protocol

MAINAIR commissioning protocol			
Manufacturer:	Plumber	Building project/operator	
System structure:	MAINAIR 300 MAINAIR 400 MAINAIR 400 K1	Insulated piping system Round, flexible hose system The "excellent" flat pipe system Bypass (300/400)	
Appendices attached:	Planning documents Air volume calculation for minimum, basic and intensive ventilation Operating manual with maintenance instructions Measurement protocol (air flow setting)		
1. Visual inspection			
1.1 Installation location - frost-free	Cellar	Ground floor	Upper floors, attic/loft level
1.2 Outside air via	Wall	Roof	
1.3 Waste air via	Wall	Roof	
1.4 Mounted silencers	Outside air	Waste air	
1.5 Fitted heating coils	Preheater coils	Reheater coils	Exhaust air, supply air
1.6 Condensate connection frost free OK	yes	no	
1.7 Ground-to-air heat exchanger present	yes	no	
1.8 Operation via	3-stage switch with filter indicator	4-button remote control	Type:
1.9 Electrical installation completed	yes	no	
2. Connection check			
2.1 Pipe conduits securely and neatly mounted on the unit?	yes	no	
2.2 Wall hood and/or roof outlet mounted securely and neatly?	yes	no	
2.3 Ventilation unit filter installed neatly and correctly?	yes	no	
2.4 Supply air and exhaust air manifold firmly and neatly installed?	yes	no	
2.5 MAINAIR hoses firmly mounted on the manifold?	yes	no	
2.6 MAINAIR hoses labelled in relation to the rooms?	yes	no	
2.7 Supply and exhaust air hoses only routed within the thermal envelope?	yes	no	
2.8 Supply and exhaust air valves installed according to air volume calculation?	yes	no	
2.9 Sufficient overflow possibility between supply and exhaust air spaces as well as overflow areas, e.g. via door joint approx. 1.5 cm	yes	no	
3. Functional test			
3.1 Functional test of the ventilation system via programming unit	yes	no	
3.2 Functional test of the additional installation	yes	no	
- Preheater coils	yes	no	
- Reheater coils	yes	no	
- Switch or remote control, all levels can be selected	yes	no	
3.3 Valves set and functional test carried out (measurement protocol)	yes	no	
4. Instruction			
4.1 Device functions explained and users instructed, if necessary?	yes	no	
4.2 Programming unit explained and users instructed?	yes	no	
4.3 Filter change explained and users instructed?	yes	no	
5. Other			
5.1 Are the requirements for securing the combustion air supply met? (Required for tiled stoves, fireplaces or gas boilers, etc.; if necessary, consult the district chimneysweep)	yes	no	

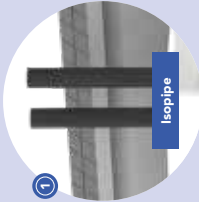
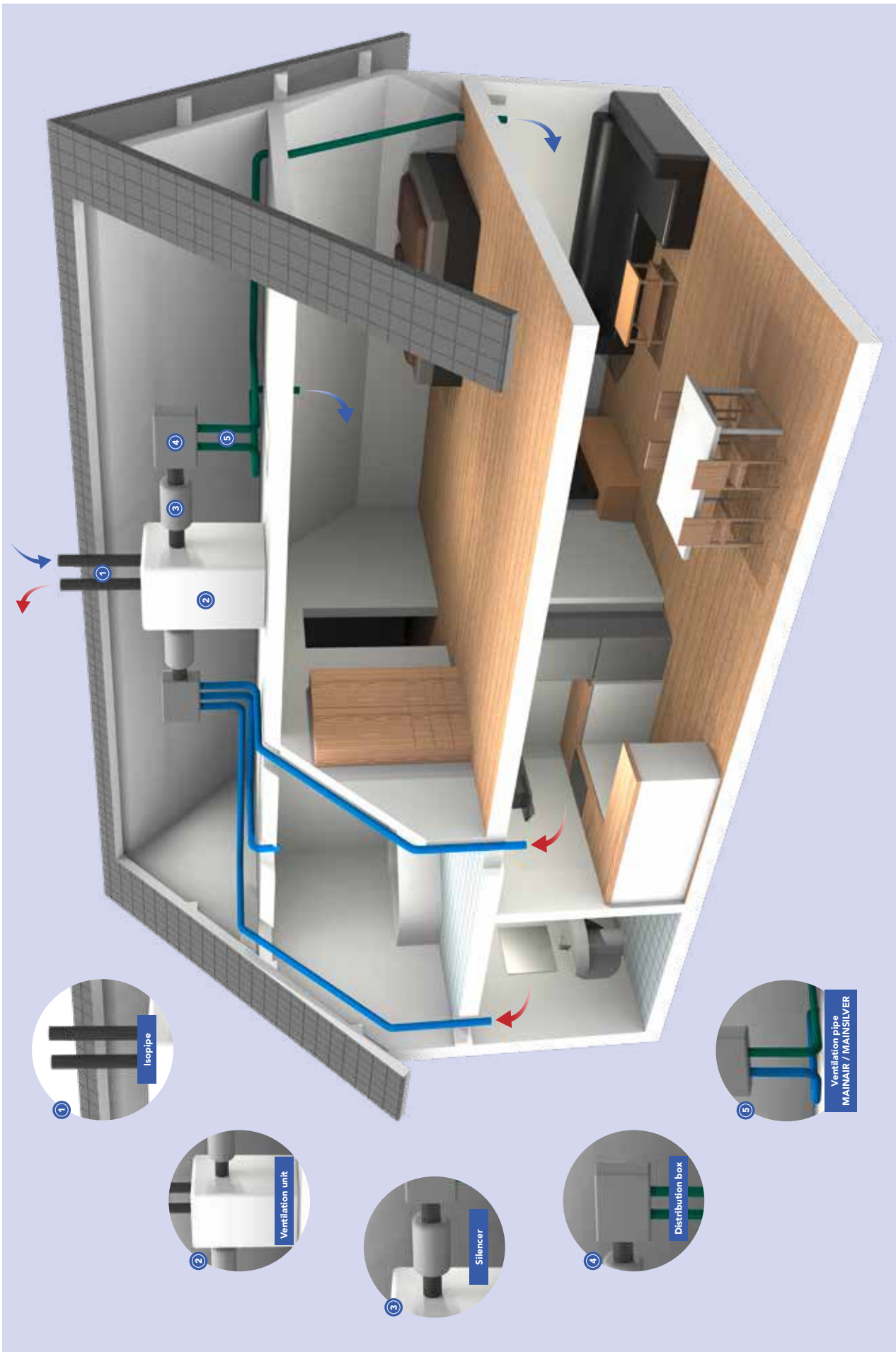

2.7 Installing system components

SILENCER

Telephony effect

The transmission of sound from room to room via the pipe system is known as the telephony effect. For this reason, it is important to install the ventilation pipe with a minimum length of 5 m. This must be taken into account in the planning of classic installation systems such as spiral seam or flat pipe systems and prevented by additional telephonic silencers.

Equipment noise

Silencers are used to reduce the transmission of equipment noise through the air distribution system.

Notes:

- A silencer must be provided in the supply and exhaust ventilation pipe between the unit and the distribution box
- If air intake or discharge is near living areas, quiet rooms or adjacent buildings, the use of device silencers is also recommended on the outside/waste air side.

Warning:

The connection diameter of the silencer must not be less than the diameter of the pipe used to connect the ventilation unit to the distribution boxes!

3. MAINAIR & MAINSILVER ventilation pipes

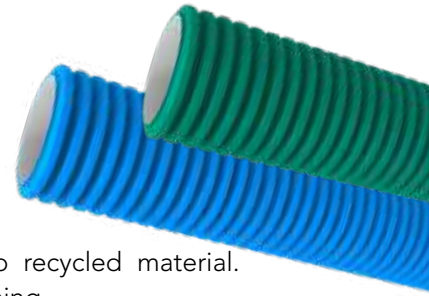

General

For our inhouse-produced ventilation pipes, we only use pure new material, no recycled material. The smooth inner surfaces of the pipes enable low flow resistance and optimum cleaning.

MAINAIR - flexible ventilation pipe



Product details

Description/Dim.	Code	PU
63 x 6.0	706.300.142.050	50 m
75 x 6.5	707.500.142.050	50 m
90 x 7.5	709.000.142.050	50 m

Field of application

Ventilation pipe used both as supply and exhaust pipe in premises featured with a central ventilation system; flexible ventilation pipe in corrugated pipe with smooth inner layer surface; hygienically tested; every coil comes with two protection caps, pipe is antistatic and resistant against external loads. Above mentioned diameters comply with the demands of DIN EN 61386-24.

Technical Properties

- Raw material: PE
- Flammability: UL 94 HB - DIN 4102: B2
- Max. installation length: 15 m
- Min. working temperature: -5° C
- Surface resistance [Ω]: DIN IEC 60093 10^{13}
- Compressive strength (DIN EN 61386): 450 N
- Antistatic
- Max. continuous operating temperature: 50° C
- Min. installation length: 5 m
- Outside storage under solar radiation: max. 6 months
- Further colours on request

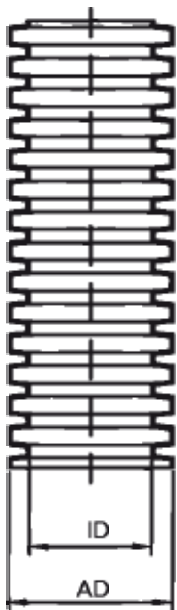

Type	Outer Ø [mm]	Inner Ø [mm]	Bending radius [mm]
63 x 6.0	63	52	45
75 x 6.5	75	62	70
90 x 7.5	90	75	70

Pressure loss curves

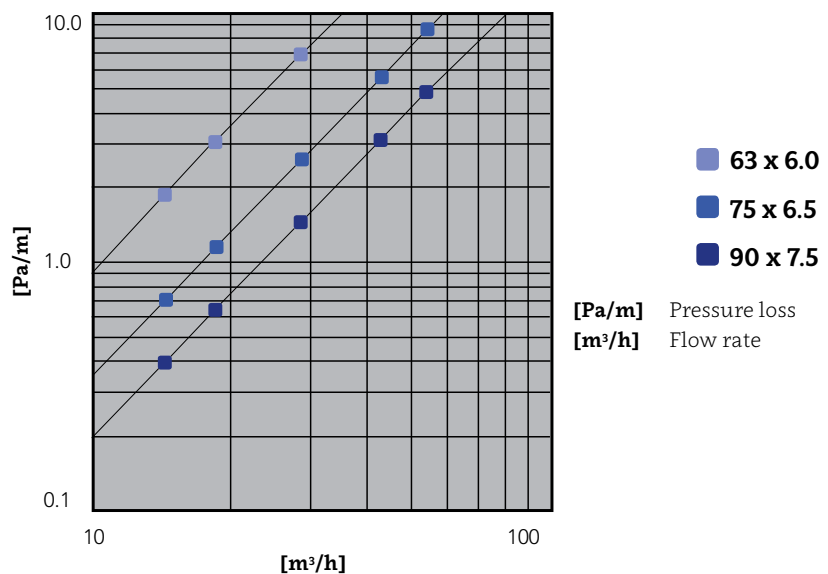

MAINSILVER - flexible antibacterial ventilation pipe



Product details

Description/Dim.	Code	PU
75 x 6.5	7A7.500.185.050	50 m

Field of application

Certified, antibacterial ventilation pipe for use as a supply or exhaust air pipe in rooms with central systems for controlled domestic ventilation. Corrugated outside, smooth inside; hygienically tested; pipe with protective cap, outer pipe pressure-resistant, inner pipe low-noise and antistatic due to inner layer. The above-mentioned pipes meet the requirements of DIN EN 61386-24.

Other nominal widths on request.

Technical Properties

- Antibacterial
- Antistatic
- Raw material: PE
- Surface resistance [Ω]: DIN IEC 60093 $<10^{13}$
- Flammability: UL 94 HB
- Max. continuous operating temperature: 50° C
- Max. installation length: 15 m
- Min. installation length: 5 m
- Min. working temperature: -5° C
- Outside storage under solar radiation: max. 6 months
- More colours on request
- Compressive strength (DIN EN 61386): 450 N

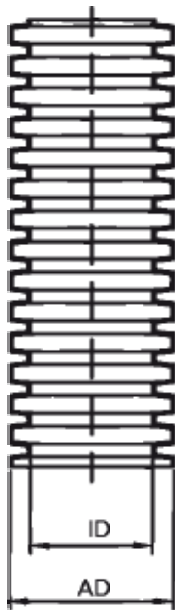

Type	Outer Ø [mm]	Inner Ø [mm]	Bending radius [mm]
75 x 6.5	75	62	70

Pressure loss curve

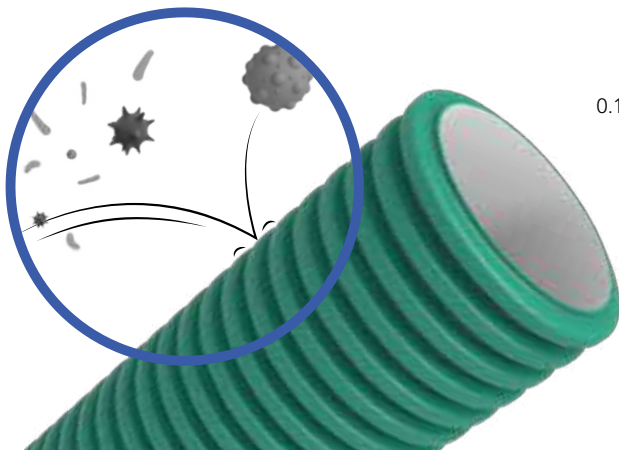
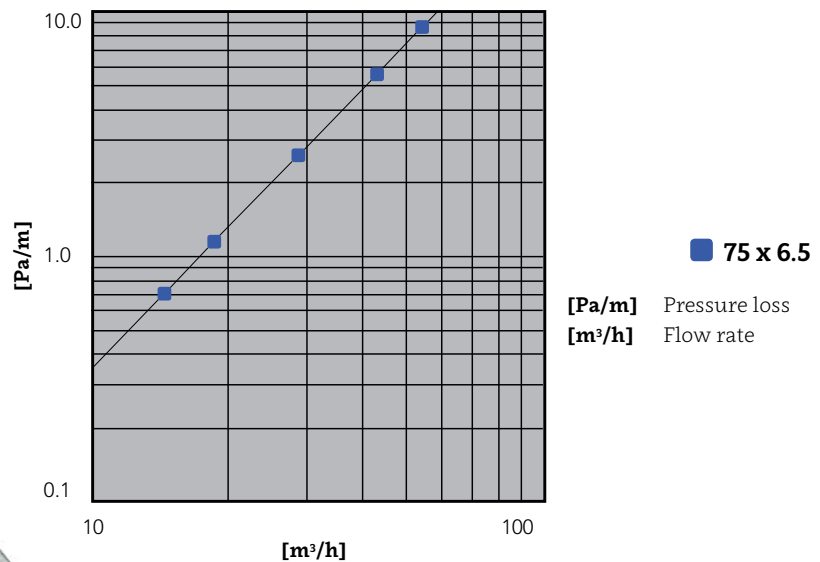







4. Ventilation connection and distribution channels

General

90° plastic air connection housing for wall and ceiling mounting (filigree corners). The valve deflector pieces are made entirely of polyethylene. This creates smooth surfaces with a low component weight, which reduces noise and simplifies assembly. In addition, the polyethylene has been modified to be antistatic to prevent dust deposits. Due to its design the pipe has excellent flow properties.

! Note: Ventilation connection and distribution channel is delivered without plug.

-  Raw material: PE-HD
-  Integral mounting eyelets
-  Flammability: UL 94 HB - DIN 4102: B2
-  Antistatic
-  Simple assembly
-  Low-noise
-  Optimised flow rate

Ventilation connection and distribution channel, single

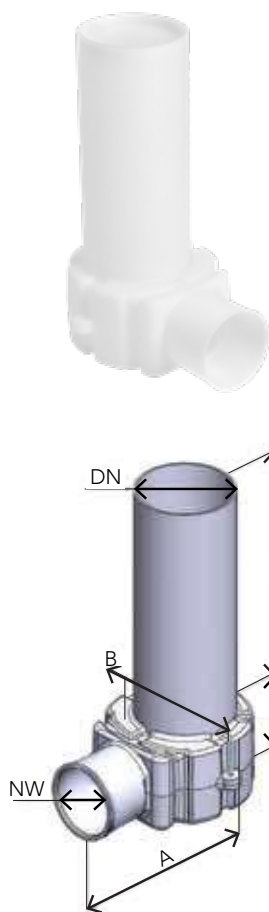

Product details

Description/Dim.	Code	L2	PU
NW 125 / 75	80.000.129	300	1 pc

Pressure loss curve

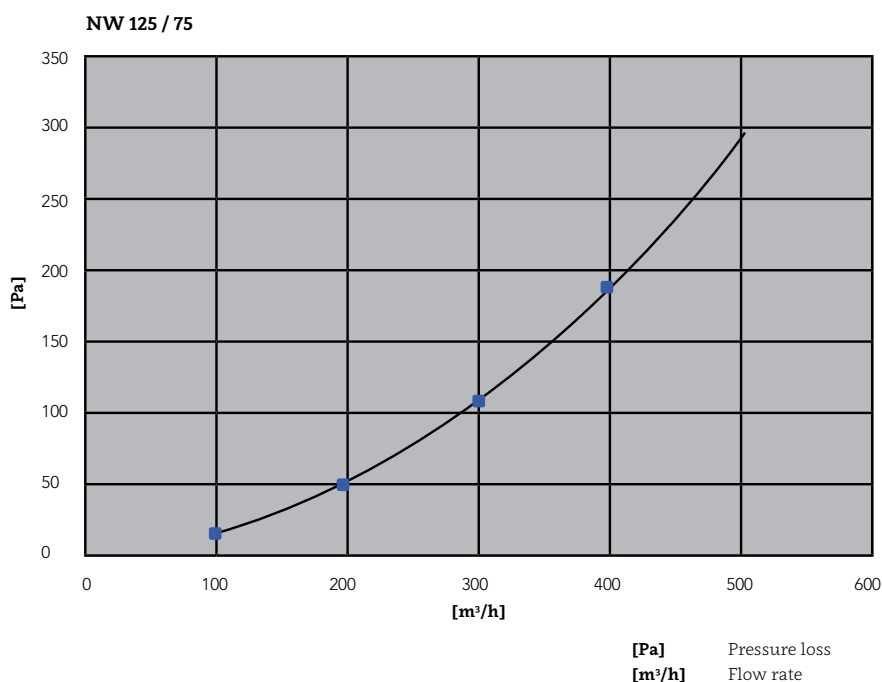

Type	Version	A	B	L1	L2
NW 75	DN 125	275	180	85	200/300

Ventilation connection and distribution channel, double



Product details

Description/Dim.	Code	L2	PU
NW 125 / 63 / 63	80.000.106	300	1 pc
NW 125 / 75 / 75	80.000.105	300	1 pc

Pressure loss curves

NW 125 / 63 / 63

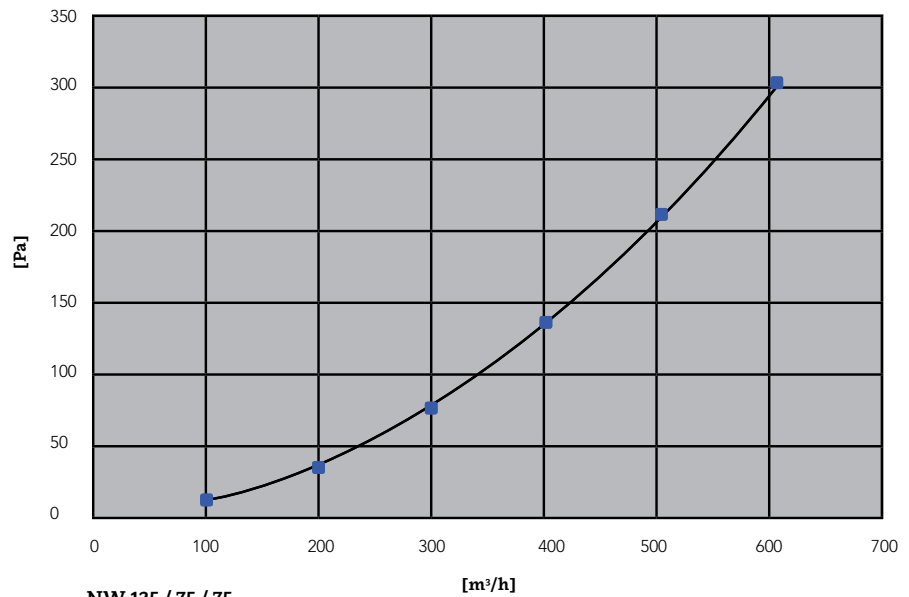

NW 125 / 75 / 75

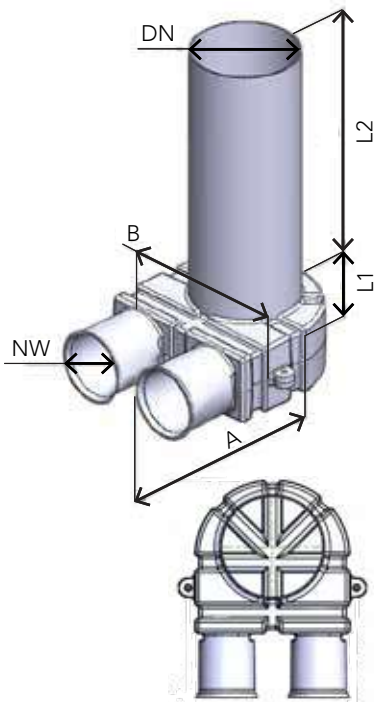
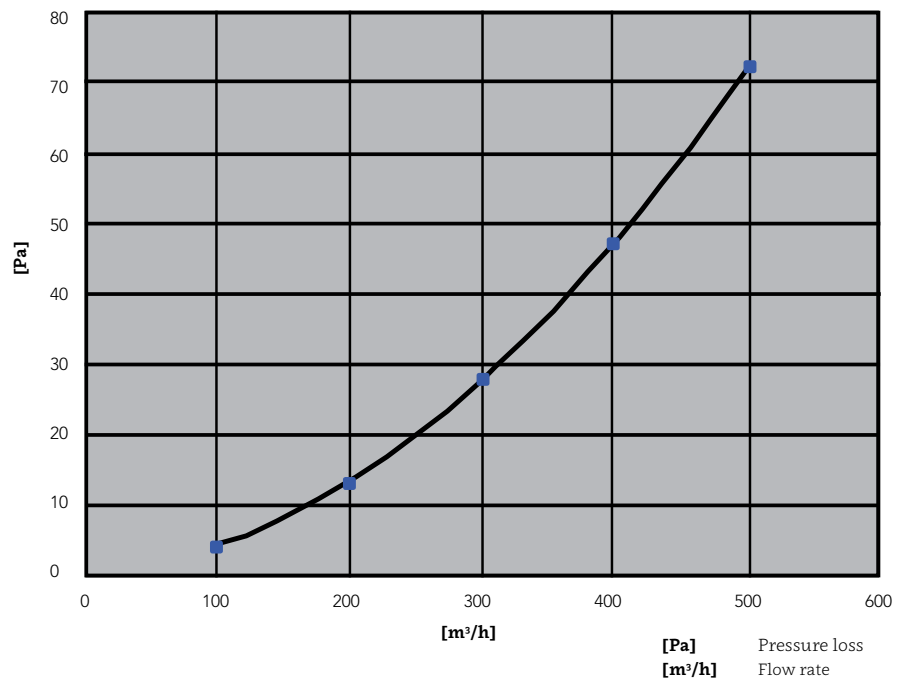

Type	Version	A	B	L1	L2
NW 63	DN 125	272	194	78	200/300
NW 75	DN 125	278	208	84	200/300

Ventilation connection and distribution channel, axial

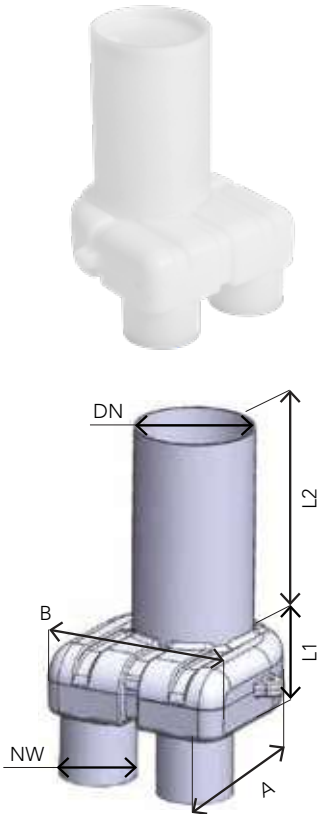

Product details

Description/Dim.	Code	L2	PU
NW 125 / 75 / 75	80.001.117	200	1 pc

Pressure loss curve

NW 125 / 75 / 75 Axial

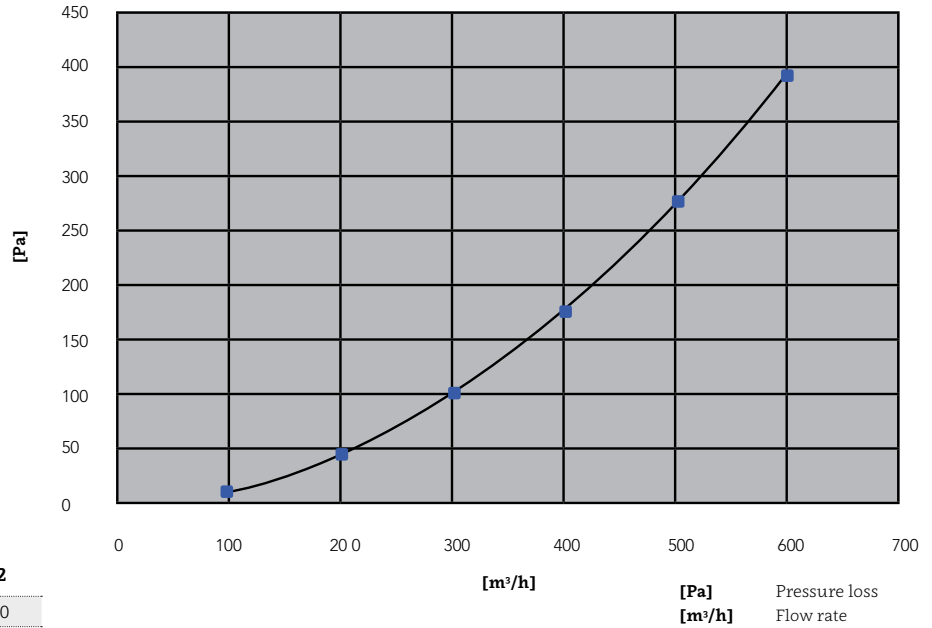

Type	Version	A	B	L1	L2
NW 75	DN 125	225	210	70	200

INSTALLATION INSTRUCTIONS

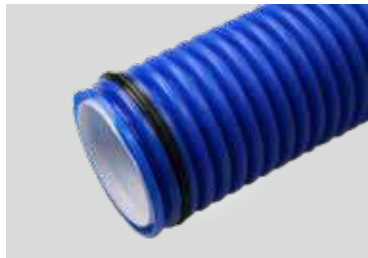

Insert the seal ring into the second groove of the ventilation pipe, without twisting.



To facilitate the installation of the ventilation pipe, we recommend commercially available lubricant (silicone spray or other odourless food greases).



Insert pipe as far as it will go.



Wrap connection with cold shrink tape.

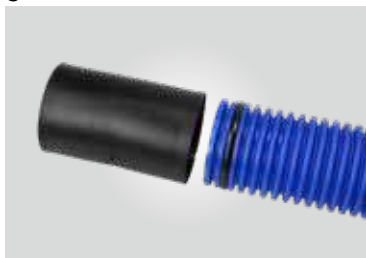

Two pipes can easily be connected via a double connection sleeve.

General note:

To ensure even air distribution and adjustment, the pipe section must be at least 5 m to a maximum of 15 m.

5. Distribution boxes

General

! Note: Distribution box is delivered without plug.

- Raw material: PE-HD
- Flammability: UL 94 HB - DIN 4102: B2
- Simple assembly
- Optimised flow rate
- Integral mounting eyelets
- Antistatic
- Low-noise



Distribution box, plastic - NW63

Product details

Type	Version	A	B	L1	Description/Dim.	Code	PU
NW 63	DN 125	620	565	136	63-125-W Pipe connector DN 125: Outflows 6 pipe ends; DN 63	80.100.040	1 pc
NW 63	DN 160	626	564	239	63-160-W Pipe connector DN 160: Outflows 12 pipe ends; DN 63	80.100.042	1 pc
NW 63	DN 180	637	565	346	63-180-W Pipe connector DN 180: Outflows 18 pipe ends; DN 63	80.100.044	1 pc

Pressure loss curves

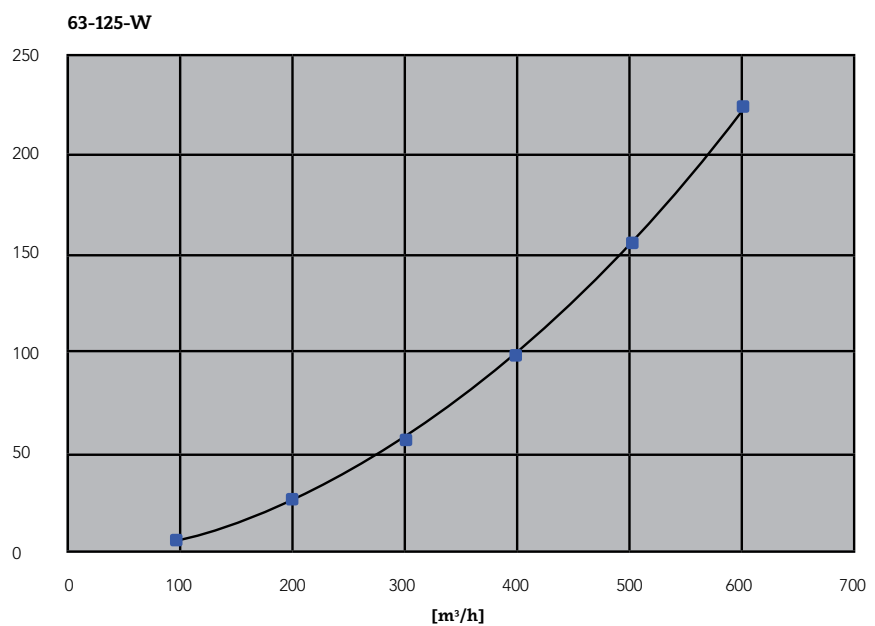
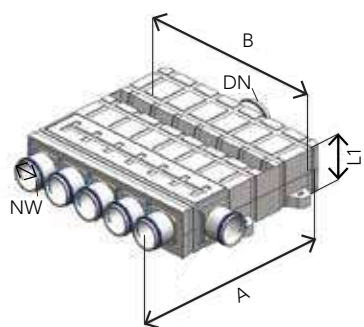

[Pa] Pressure loss
[m³/h] Flow rate

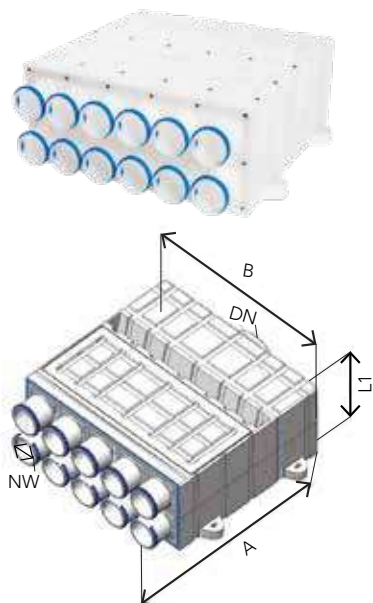

63-160-W

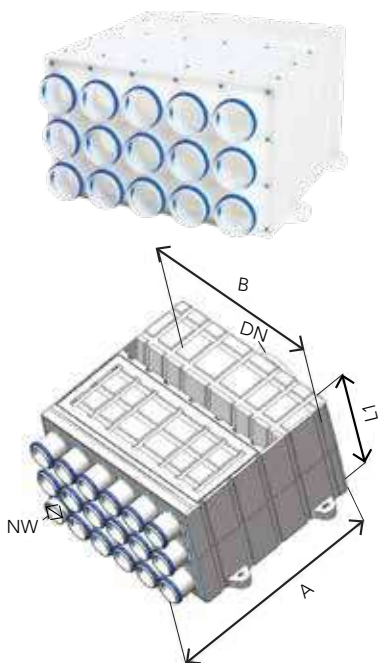
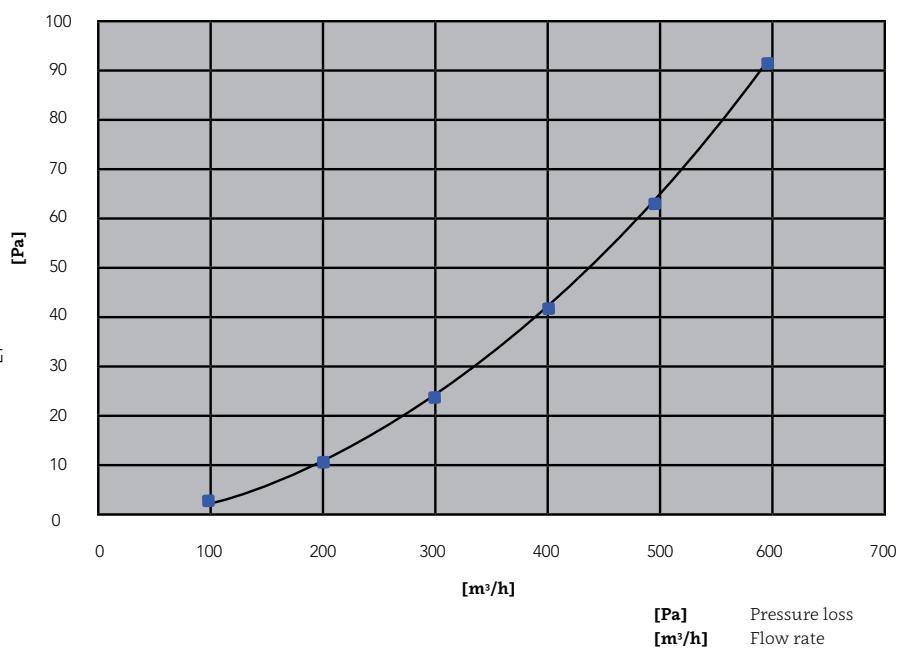

63-180-W

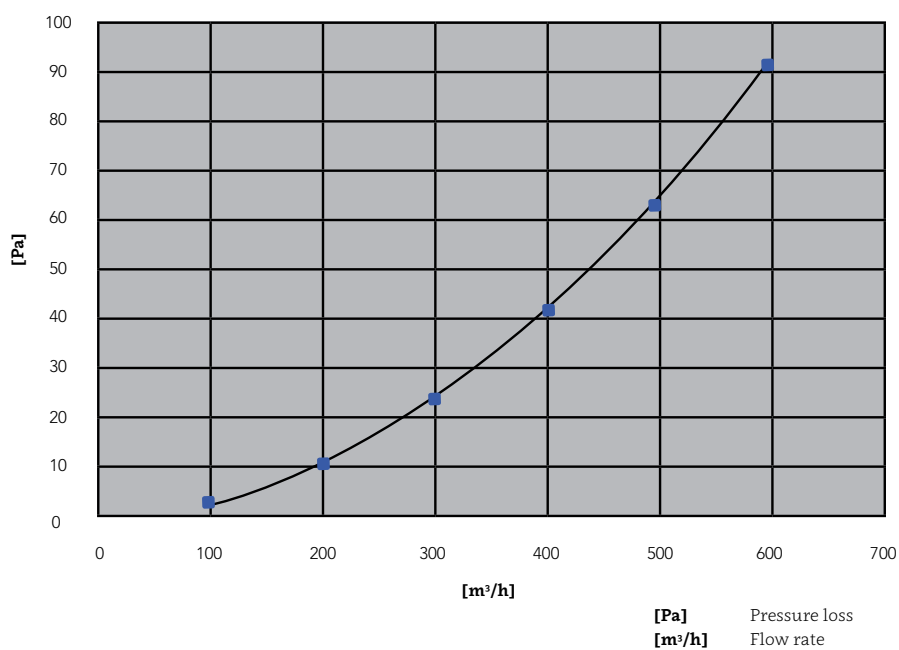

Distribution box, plastic - NW75

Product details

Type	Version	A	B	L1
NW 63	DN 125	620	565	136
NW 63	DN 160	626	564	239
NW 63	DN 180	637	565	346

Description/Dim.	Code	PU
75-125-W Pipe connector DN 125: Outflows 5 pipe ends; DN 75	80.100.041	1 pc
75-160-W Pipe connector DN 160: Outflows 10 pipe ends; DN 75	80.100.043	1 pc
75-180-W Pipe connector DN 180: Outflows 15 pipe ends; DN 75	80.100.045	1 pc

Pressure loss curves

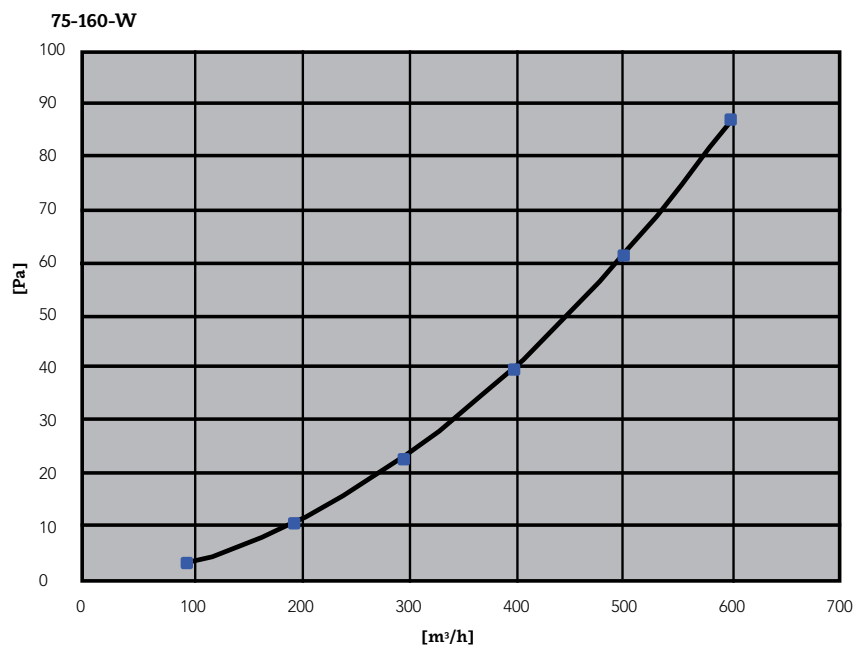
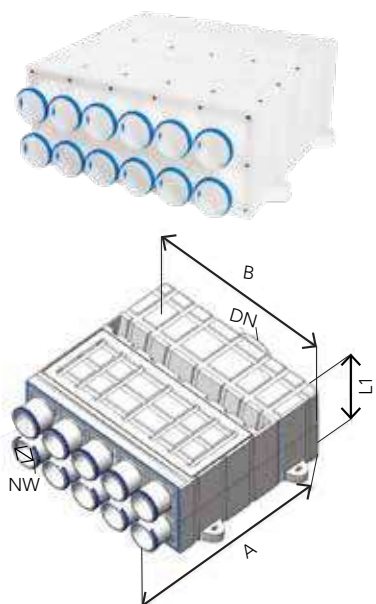
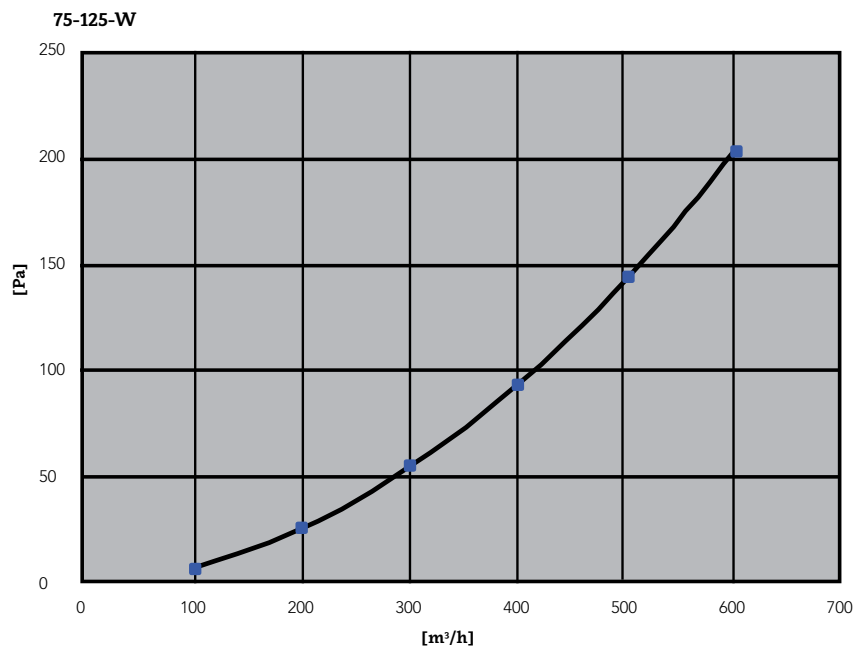
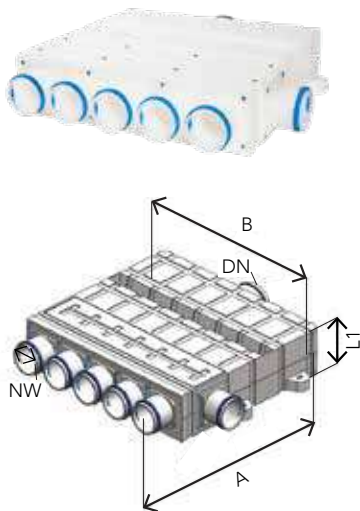

[Pa] Pressure loss
[m³/h] Flow rate

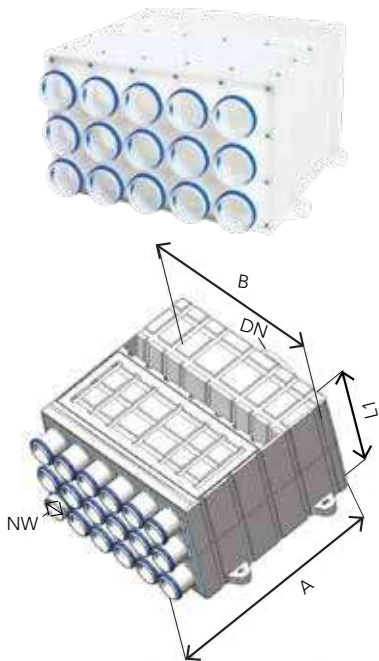

75-180-W

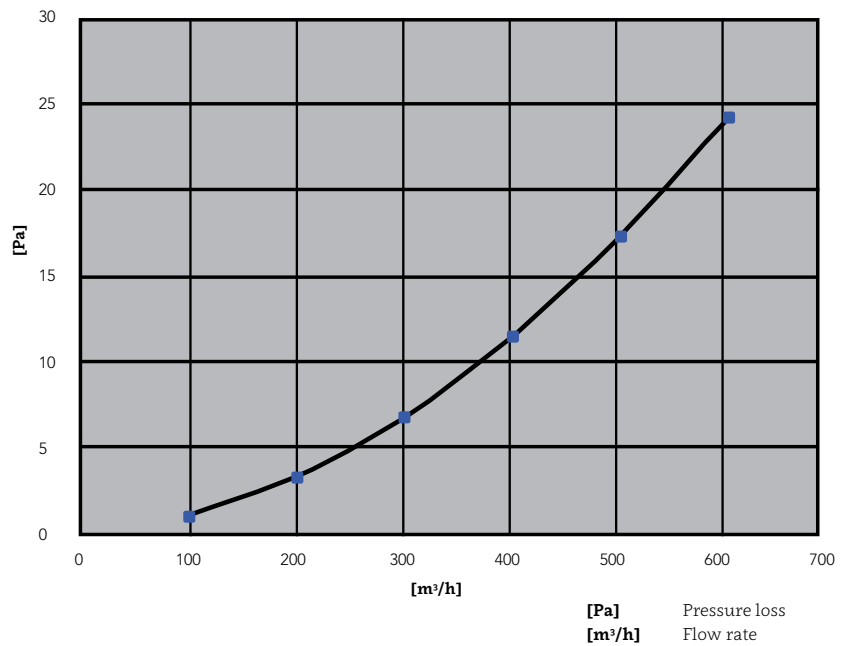

Installation instructions:

- Ideally place the distribution box near the unit.
- The inspection aperture should be easily accessible at all times.
- Connectors that are not required must be covered with sealing caps.
- Simple attachment of the manifold to the wall or ceiling by means of integrated mounting brackets.



Insert the seal ring into the second groove of the ventilation pipe, without twisting.



Release the safety clip on the distribution box.



Push the ventilation pipe into the manifold as far as it will go and reattach the safety clip.

6. Accessories

Double connection sleeve



Product details

Description/Dim.	Code	PU
NW 63	39.100.063	1 pc
NW 75	39.100.075	1 pc
NW 90	39.100.090	1 pc

Double connection sleeve for MAINAIR and MAINSILVER ventilation pipe with locking device for airtight connection of the ventilation pipe.

Minimum order quantity 1 piece

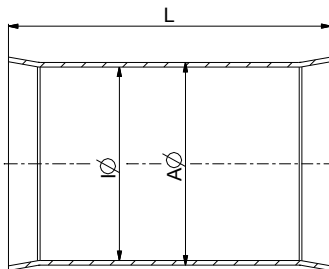

Type	Ø	IØ	L
NW 63	66 (±1)	63 (±1)	107
NW 75	82 (±1)	76 (±1)	130
NW 90	97 (±1)	91 (±0.5)	150

Handling instructions

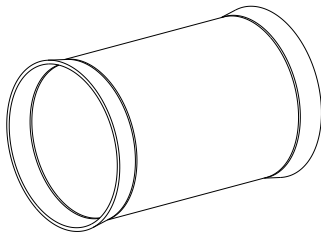

Insert the seal ring into the second groove of the ventilation pipe.



Connect the ventilation pipe to the double connection sleeve using commercially available lubricant.



As in step 2, connect the other side of the double connection sleeve to the ventilation pipe.



DONE!

Supply air valve / Exhaust air valve



Product details

Description/Dim.	Code	PU
Supply air valve 125	80.380.02	1 pc
Exhaust air valve 125	80.380.04	1 pc

White plastic valve with rubber lip seal for mounting in ventilation pipes or valve deflectors, Ø125 mm supply air/exhaust air version. The volumetric flow rate can be continuously adjusted using the rotatable valve disk; the valve disk can be fixed by a lock nut.

The device is made of recyclable polypropylene plastic and can withstand temperatures up to 100°C. The materials used in the device are resistant to most chemicals in low concentrations. The device is supplied in RAL9002.

The unit can be cleaned with a cloth moistened with a mild detergent or synthetic detergent.

Pressure loss curves

1 Supply air

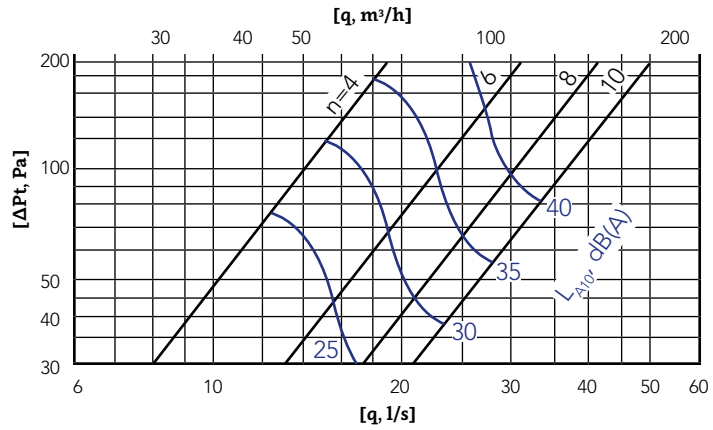
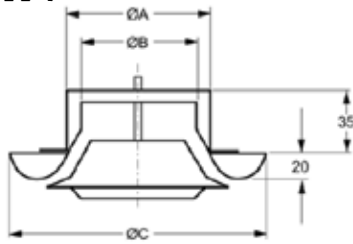

2 Exhaust air

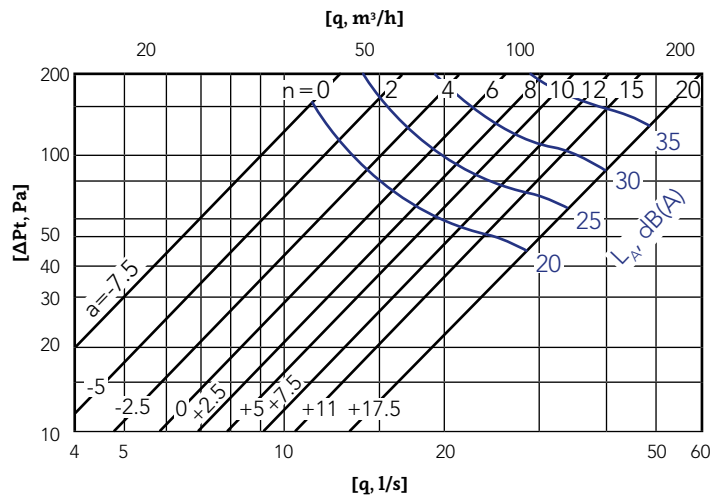
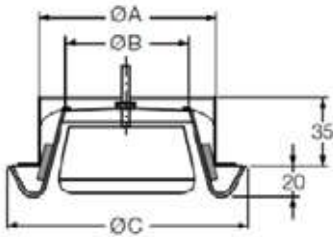

Type	ØA [mm]	ØB [mm]	ØC [mm]	Weight [kg]
Supply air 125	125	96	158	0.16
Exhaust air 125	125	95	160	0.15

6.1 Supply and exhaust valve positioning

From a hygienic perspective, it is a good idea to have air flow from the living rooms and bedrooms to the functional spaces of the bathroom, kitchen and toilet, with the corridor serving as an overflow area (mechanical transverse ventilation). In order to ensure air flow from the supply air areas to the exhaust air areas, the inner door serves as an air passage (door gap min. 1 cm). Air inlets and outlets differ in size and shape. Here it is necessary to determine the appropriate elements with regard to noise level, volume flow and flow propagation.

Notes on positioning the supply air elements

Supply air elements can be placed in the ceiling, wall and floor. Pay attention to the flow propagation properties of the supply air elements. Supply air valves should be positioned as far as possible from the overflow openings (door). This achieves a good flow through the room. Furthermore, care must be taken to ensure that there are no draughts when sitting or lying down (bed). The distance should be at least 1 meter. Ensure that the supply air elements are not covered (e.g. by curtains or cabinets). In the case of supply air valves, ensure a sufficient distance from the corner of the room; this should be at least 60 cm.

Notes on positioning the exhaust air elements

Exhaust air elements can be positioned in the wall, but they work better on the ceiling. For wall mounting, the distance to the ceiling should not be more than approx. 20 cm. In principle, positioning should be in the immediate vicinity of sources of odours and moisture, but not directly above showers or bathtubs, as otherwise draughts may occur (displacement ventilation principle). Positioning directly above a heat source (radiator) is also discouraged.

ATTENTION!

Do not position directly above the oven.

Assembly instructions



Isopipe





Product details

Isopipe	Code	Length	PU
DN 125	80.480.15	2,000 mm	1 pc
DN 160	80.480.16	2,000 mm	1 pc
DN 180	80.480.17	2,000 mm	1 pc

Soundproof and thermally insulated pipe.

Dimensions

-  DN 125: Inner diameter 125, outer diameter 155
-  DN 160: Inner diameter 160, outer diameter 190
-  DN 180: Inner diameter 180, outer diameter 210

Technical Properties

-  Pipe material: EPE foam, vapour-proof
-  Heat-penetration resistance: 0.36 m²K/W
-  Density: 60 kg/m³
-  Operating temperature: -15°C to +80°C
-  Colour: grey
-  Coupling sleeve material: HDPE



Product details

Isopipe elbow 45°	Code	PU
DN 125	80.480.03	1 pc
DN 160	80.480.19	1 pc
DN 180	80.480.39	1 pc

Soundproof and thermally insulated elbow, 45°.



Product details

Isopipe elbow 90°	Code	PU
DN 125	80.480.02	1 pc
DN 160	80.480.18	1 pc
DN 180	80.480.40	1 pc

Soundproof and thermally insulated elbow, 90°.



Product details

Isopipe plug-in connector	Code	PU
DN 125	80.480.01	1 pc
DN 160	80.480.20	1 pc
DN 180	80.480.41	1 pc



Product details

Reducer for Isopipe	Code	PU
DN 160/125	80.480.23	1 pc
DN 180/125	80.480.13	1 pc
DN 180/160	80.480.14	1 pc

Advantages of Isopipe over insulated spiral tubing:

- Easy assembly and handling
- Faster assembly
- Less work - no need for deburring, screwing and sealing
- Pluggable connections fit precisely

Field of application:

As replacement for spiral tubing; for air routing

a) from the unit to the waste air outlet or outside air inlet

b) from the unit to the MAINAIR plastic distribution box

Assembly instructions



Loosen the sleeve of the connector.



Push the connector onto the Isopipe elbow. Attention! It must be pushed onto the elbow till it stops.



Leave the connector sleeve open.



Then slide the Isopipe onto the connector as in step 2 until it stops.



Close sleeve. This creates an airtight connection between the two Isopipe articles.

Cutter for ventilation pipe



Product details

Description/Dim.	Code	PU
DN 75 & 90	80.807.590	1 pc

Our cutter for ventilation pipes enables safe, quick and easy cutting. A straight cut on the pipe makes it much easier to connect to the manifold and deflector pieces.

Suitable for dimensions 75 and 90.
Gross weight: 97 g

Handling instructions



Locked Unlocked



NW 75 NW 90



Pass once around pipe in cutting direction



DONE!

Lead pan



Product details

Description/Dim.	Code	PU
BP 125-160-W	80.730.13	1 pc
BP 180-W	80.730.20	1 pc
BP 125-160-WR*	80.730.45	1 pc

Lead pan, universal, black. Suitable for roof inclinations of between 25° and 45°.

*Lead pan, universal, red. Suitable for roof inclination from 25° to 45° and DN 125 and DN 160.

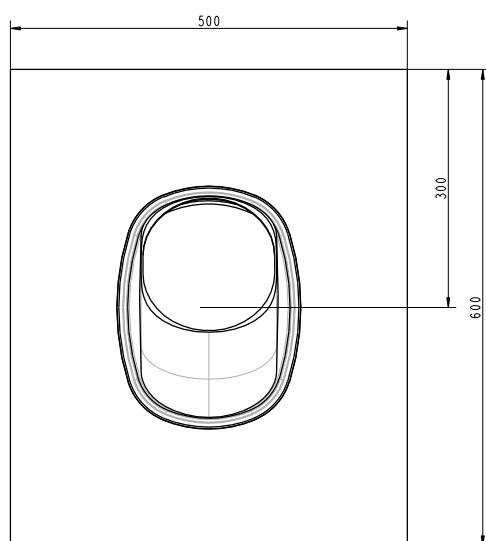
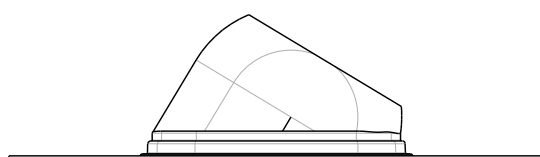

SCALE 1:5

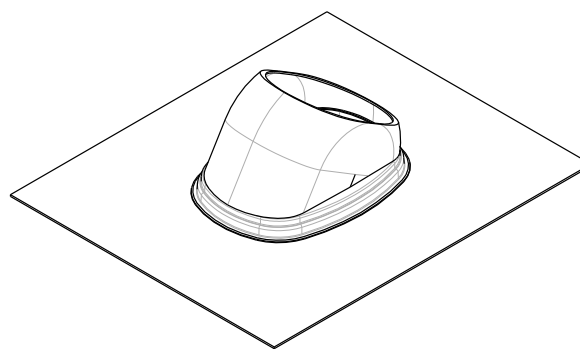
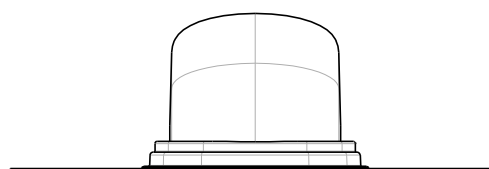

SCALE 1:5

Operating modul BM-2 with eBUS interface



Product details

Description/Dim.	Code	PU
Operating modul BM-2 with eBUS interface	80.372.12	1 pc
Wall base for BM-2	80.372.13	1 pc

Room/weather-compensated temperature controller with schedule for the CWL-2-400 series of domestic and ventilation units, heating, hot water and Wolf solar thermal systems. 3.5" colour display for easy programming and display of all important data. Mounting in wall base as remote control, eBUS interface, without outside temperature sensor.

Wall base for use of the BM-2 control modul as a remote control.



Procedure for faults

- Read fault message
- Determine and eliminate the cause of the fault
A fault can be reset via key 4 on the message status page.
- Check system for correct function

Ventilation unit status page - Advanced mode



Displayed only when a CWL-2-400 is connected to the room control system.
Warning: Parallel operation with a local control modul is not possible!

Changing the operating mode / Start - End / ON - OFF



Back to home page



7. Ventilation unit

MAINAIR CWL-2-400

with Passive House certification and DIBT approval



Product details

	Description/Dim.	Code	PU
①	MAINAIR CWL-2-400 2/2R	80.100.022	1 pc
①	MAINAIR CWL-2-400 4/0R	80.100.023	1 pc

Scope of delivery:

- 1 x heat recovery device
- 1 x wall mounting set (comprising: 1 x mounting bracket, 2 x spacers, 2 x rubber strips, 2 x rubber disks)
- 1 x siphon
- 1 x installation instructions

Description:

Maintenance-friendly central ventilation unit with highly efficient plastic cross-counterflow plate heat exchanger, integral automatic bypass damper and modulating electric preheater coil (1000W). The centrifugal supply and exhaust air fans ensure a constant and precise flow rate.

2/2R:

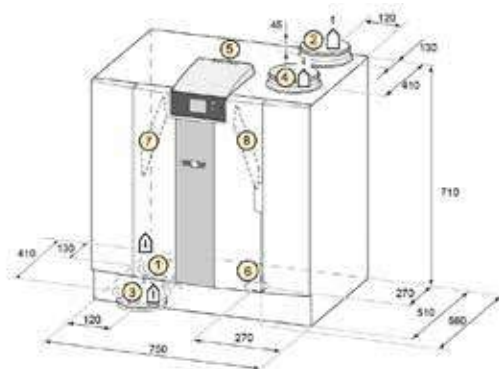

4/0R:

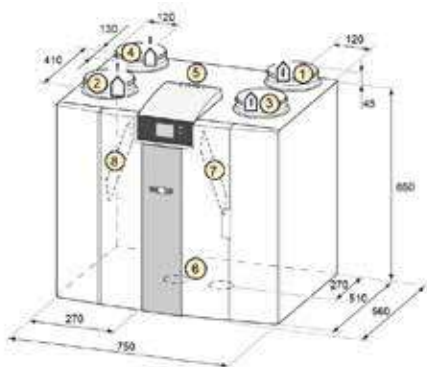

Product features of the CWL-2-400 at a glance:

- Maximum output 400 m³/h
- High efficiency plastic heat exchanger
- ISO coarse filter 60%
- Modulating electric preheater coil
- Automatic bypass damper
- Touch screen
- Adjustable air volumes
- Filter display on the unit and option of filter display on the level switch
- Intelligent frost protection control including integral modulating preheater coil
- Low noise level
- Constant flow control

No additional PCB is required for external sensors/devices (e.g. reheater coils).

All external sensors/devices can be clamped directly to existing clamping locations.

- Air throughput [m³/h]: max. 400
- Supply voltage [V/Hz]: 230 V/50 Hz
factory set with 230 V mains plug
- Heat supply level: 97%
- Weight: 38.5 Kg
- Filter class: ISO coarse 60%
(ISO ePM1.0 50% for supply air optional) Special filter on request
- Connection diameter [mm]: 180
- Ext. pressure increase [Pa]: 200 at 400 m³/h
- Power consumption [W]: 7.6 – 160.8
without preheater coil
- Power consumption [A]: 0.12 - 1.25
without preheater coil
- Max. current consumption [A]: 6
with switched on preheater coil
- Protection category: IP30
- Height / Width / Depth [mm]: 750 / 710 / 560 (2/2R)
750 / 650 / 560 (4/0R)

Properties

Operating voltage [V/Hz]	230/50				
Protection category	IP30				
Dimensions (W x H x D) [mm]	750 x 650 x 560 (4/0R) / 750 x 710 x 560 (2/2R)				
Duct diameter [mm]	Ø 180				
Outer diameter of condensate drain [mm]	Ø 32				
Weight [kg]	38.5				
Filter class	ISO coarse 60% (ISO ePM1.0 50% for supply air optional)				
Fan stage (factory setting)	0	1	2	3	max
Ventilation capacity [m³/h]	50	100	200	300	400
Permissible drag in pipe system [Pa]	2 - 4	6 - 16	25 - 63	56 - 141	100 - 200
Power consumption [W] (without preheater coil)	7.6 - 7.8	10.3 - 11.5	23 - 31.4	62.5 - 87	126.6 - 160.8
Current consumption [A] (without preheater coil)	0.12	0.15 - 0.16	0.25 - 0.33	0.58 - 0.77	1.01 - 1.25
Max. current consumption [A] (with switched on preheater coil)	6	6	6	6	6
Cos φ	0.270 - 0.272	0.300 - 0.310	0.369 - 0.410	0.470 - 0.493	0.545 - 0.560

Sound power

Air throughput [m³/h]	150	250	350	400	
Sound power level L _w (A)	Static pressure [Pa]	25	50	100	100
	Noise emissions of the housing [dB(A)]	37	43.5	52	55
	Exhaust ventilation pipe* [dB(A)]	43.5	46.5	51	61
	Supply ventilation pipe* [dB(A)]	50	58	59.5	71

* Duct noise including final correction

In practice, the value may differ by 1 dB(A) due to measurement tolerances.

Product data sheet CWL2-400 according to Ecodesign (ErP), No. 1254/2014 (Appendix I\V)

Manufacturer: Wolf GmbH					
Model: CWL -2-400					
Climate zone	Control unit type	Specific energy consumption value in kWh/m ² /a	Specific energy consumption class	Annual electricity consumption in kWh	Annual heating energy savings
Medium	Manual operation	-40.68	A	258	4646
	Time control	-41.33	A	237	4658
	1x sensor (rF/CO ₂ /VOC)	-42.54	A+	199	4684
	2 or more sensors (rF/CO ₂ /VOC)	-44.65	A+	135	4735
Cold	Manual operation	-79.74	A+	795	9088
	Time control	-80.50	A+	774	9113
	1x sensor (rF/CO ₂ /VOC)	-81.96	A+	736	9163
	2 or more sensors (rF/CO ₂ /VOC)	-84.56	A+	672	9263
Warm	Manual operation	-15.68	E	213	2101
	Time control	-16.26	E	192	2106
	1x sensor (rF/CO ₂ /VOC)	-17.33	E	154	2118
	2 or more sensors (rF/CO ₂ /VOC)	-19.16	E	90	2141
Ventilation unit type		Ventilation unit with heat recovery			
Fan		EC stepless fan			
Heat exchanger type		Recuperative plastic counterflow heat exchanger			
Thermal efficiency		92%			
Maximum air throughput		400 m ³ /h			
Maximum power consumption		193 W			
Sound power level L _{wa}		50 dB(A)			
Reference air throughput		280 m ³ /h			
Reference pressure		50 Pa			
Specific power consumption (SEL)		0.17 Wh/m ³			
Control factor		1.0 in combination with level switch			
		0.95 in combination with time control			
		0.85 in combination with 1 sensor			
		0.65 in combination with 2 or more sensors			
Leakage*	Internal	2.85%			
	External	2.85%			
Filter warning indicator		In the display of the unit / on the level switch (LED) / on the control modul BM-2! Attention! Regular inspection and possibly cleaning or replacement of the filters is necessary for optimum energy efficiency and perfect functioning.			
Website for installation instructions		www.wolf.eu			
Bypass		Yes, 100% bypass			

*Measurements performed by TZWL according to EN 13141-7

Classification from 1. January 2016

Specific energy consumption class ("medium climate zone")	Specific energy consumption in kWh/m ² /a
A+ (highest efficiency)	Specific energy consumption < -42
A	-42 ≤ Specific energy consumption < -34
B	-34 ≤ Specific energy consumption < -26
C	-26 ≤ Specific energy consumption < -23
D	-23 ≤ Specific energy consumption < -20
E (least efficient)	-20 ≤ Specific energy consumption < -10



GERMANY

Hotline: +49 9721 659 77-100

Fax: +49 9721 659 77-200

Homepage: www.maincor.de

E-Mail: info@maincor.de

MAINCOR Rohrsysteme GmbH & Co. KG

Silbersteinstraße 14

97424 Schweinfurt