



Mainpex

Sliding sleeve system



THE TECHNICAL MANUAL

Mainpex

Sliding sleeve system

All legal and technical information has been carefully compiled to the best of our knowledge. No liability can be accepted for any errors or omissions. This document including the contents is protected by copyright. Any use prohibited by copyright is not allowed without the permission of MAINCOR Rohrsysteme GmbH & Co. KG. All rights reserved. In particular reprinting, editing, storage and processing in electronic systems, translations and microfilms. Subject to printing errors and technical changes. All previous versions lose their validity. Please consider legal provisions, technical regulations, approvals and standards.

1.	General	4
1.1	Description of the system	4
1.2	General notes	5
2.	System components	6
2.1	The pipe	6
2.2	The fitting	7
2.3	Resistance coefficients in accordance with DIN 1988-300	8
3.	Processing	9
3.1	Fitting assembly	9
3.2	Bends	10
3.3	Pipe laying and fastening	11
3.4	Insulation of MAINPEX pipes	13
3.5	Fire protection	15
3.6	Sound insulation	17
3.7	General laying guidelines	18
3.8	Heating installations with MAINPEX	20
3.9	Sanitary installations with MAINPEX	22
4.	Drinking water supply	24
4.1	Drinking water	24
4.2	Drinking water distribution	25
5.	Rinsing and pressure testing	26
6.	Tables	34
7.	Standards	42
8.	Certificates and guarantees	43

1. General

1.1 Description of the system

Area of application

The MAINPEX system sets standards in processing and application in the area of heating and sanitation. It is ideal for quick and secure assembly; it is easy to bend but nevertheless structurally stable.

The different heating and sanitation systems for residential and office buildings must fulfil a range of different requirements. The areas of application for multi-storey heating systems, central heating systems in the form of low temperature heating systems (LT heating systems) and sanitation systems are covered by professional planning, design and conception of the components of the MAINPEX system.

LT heating systems are created so that the flow temperature automatically adapts to the outside temperature. The maximum temperature does not exceed 70°C, whereas the minimum temperature can fall to 30°C. Therefore, fewer pipeline and standby losses result as the temperature difference to room temperature and from the outside temperature is smaller.

Energy saving potential

Due to the applicable EnEV (Energy Saving Ordinance), the system can implement optimum solutions with an economically justifiable expenditure. Effective energy saving can be achieved using a clever combination of modern technology for the necessary heat production as well as our MAINPEX composite pipe system.

Environment

As well as the aspects already referred to, a heating system today must also be considered from the point of view of environmental protection. Environmental protection concepts are taken into account through the use of environmentally-friendly materials and the practically waste-free assembly.

MAINPEX - The multi-layer composite pipe

The MAINPEX composite pipe is a pressure-resistant multi-layer composite pipe made from PE-RT/Alu/PE-RT. Due to the 100% oxygen impermeability, this pipe is ideal for use in the area of heating and sanitation.

Self-monitoring in the form of constant control of the production line as well as external monitoring by an independent testing institute guarantee adherence to all requirements for applicable pipe standards.

1.2 General notes

The operating temperature of the MAINPEX system must be between -10°C and 70°C. Exceeding the continuous operation temperature is only intended for short periods of time. It must be ensured that the continuous operation temperature is not exceeded during regular application. The MAINPEX system may not be used in systems such as, for example, solar and district heating systems, with operating temperatures above 70°C. It must be ensured that the parameters referred to above are not exceeded in any operating situation.

The changes in length due to temperature increase must be considered when laying MAINPEX composite pipes. Expansion compensators must be installed in the case of larger changes in length of pipelines which run straight without bending legs (from approx. 20 metres).

The composite pipe is resistant to corrosion due to its material properties. In the case of professional assembly of the fitting, contact corrosion is also not to be expected, because the design of the fitting prevents a contact of the aluminium with the fitting body.

Classification of operating conditions - in accordance with ISO 10508 / DIN EN ISO 21003

Pipe performance requirements are specified for different application classes. The applicable classes are shown in the table below:

Application class	T _D		T _{max}		T _{mal}		Typical area of application
	°C	Time Years	°C	Time Years	°C	Time Years	
1	60	49	80	1	95	100	Hot water supply (60°C)
2	70	49	80	1	95	100	Hot water supply (70°C)
4	20	2,5	70	2,5	100	100	Underfloor heating and low temperature radiator connections
	40	20					
	60	25					
5	20	14	90	1	100	100	High temperature radiator connection
	60	25					
	80	10					

T = Temperature, T_D = Design temperature, T_{max} = Maximum design temperature, T_{mal} = Fault temperature

Each application class relates to a typical area of application and takes into account a service life of 50 years. Classification corresponds to the requirements in ISO 10508. All specified typical fields of application are recommendations and for guidance only.

Each application class has a corresponding permissible operating pressure of 4 bar¹, 6 bar, 8 bar or 10 bar, depending on the particular application.

¹ 1 bar = 10⁵ N/m² = 0.1 MPa applies

The concept of the application class defines the purpose of ISO 10508-4. The theoretical description of dynamic conditions within the application classes accurately reflects the reality compared to statistical data. Manufacturers, planners and installers are provided with a basis for the selection of suitable pipes for specific uses.

2. System components

2.1 The pipe



MAINPEX - Multilayer composite pipe PE-RT / Al_u / PE-RT



What are the advantages of metal composite pipes?

MAINCOR MFL multilayer composite pipes are made of overlapped welded aluminium surrounded by PE-RT layers connected by adhesives. The inner aluminium layer of MAINCOR's multilayer composite pipes leads to a higher temperature and pressure resistance in comparison to standard plastic pipes.

Technical properties

working temperature	70°C
max. temperature	95°C
pressure	10 bar
standard colour inside	transparent
standard colour outside	white
other colours	on request
pipe printing	customer-specific
packing	box or foil

Application:

- drinking water installation
- radiator connection
- wall heating
- underfloor cooling
- underfloor heating

Standards:

- DIN EN ISO 21003
- DVGW W542

Approvals:

- DVGW DW8501-BS0475

diameter	outerdiameter (mm)	wall thickness (mm)	max. coil length (m)
16 x 2,2	16 + 0,3	2,2 + 0,3	200
20 x 2,8	20 + 0,3	2,8 + 0,3	100
25 x 3,5	25 + 0,3	3,5 + 0,3	50
32 x 4,4	32 + 0,3	4,4 + 0,3	50

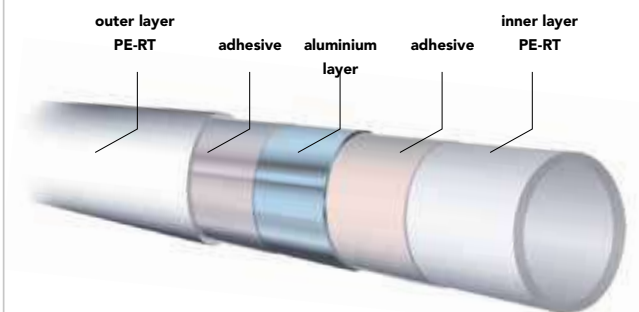

MAINCOR Rohrsysteme GmbH & Co. KG
Silbersteinstraße 14
97424 Schweinfurt

Subject to technical modifications and amendments!
Datenblatt_MSR_MPX_EN_02-22

2.2 The fitting

The MAINPEX fitting consists of CW 617N (Pb < 2.2%; Ni < 0.1%) brass in accordance with the requirements of the DVGW worksheet W 534 as well as the Drinking Water Ordinance and was developed specifically for the area of food, drinking water and heating.

The fitting is coated with a tin layer using a galvanic method. A connection of other metals with our fittings is possible without an adapter. The compliance of a special arrangement in flow direction, as known from copper or galvanised pipes, must not be considered with MAINPEX. The sliding sleeves are also galvanised to lower the risk of corrosion.

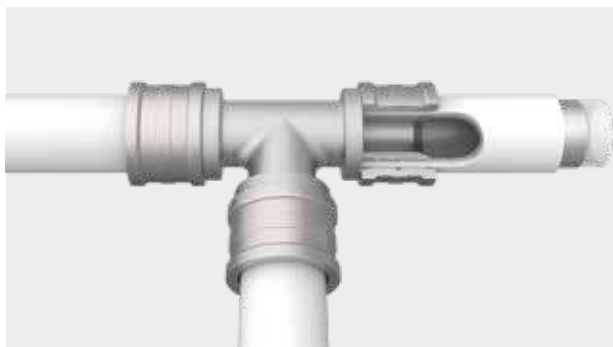

Influence / Protection of the drinking water

The MAINPRESS installation system is suitable for all drinking water qualities in accordance with the current Drinking Water Ordinance and can be used without restrictions, taking into consideration DIN 1988. The fittings are resistant to corrosion due to their material properties and correspond to the provisions of DIN 50930-6 as well as the recommendations of the Federal Environment Agency and are therefore applicable in an unrestricted manner for all drinking water in the sense of the Drinking Water Ordinance.

Corrosion

It is possible to install MAINPEX connectors in stainless steel installations, taking into consideration the recognized rules of engineering. No corrosion is to be expected in heating systems which have been executed professionally.

In case of need MAINPEX fittings have to be protected by an anticorrosive coating against corrosion caused by humidity, oxygen, saline air or aggressive environmental influences. Generally, MAINPEX fittings can be laid directly into plaster, floor screed or concrete. There are, however, exceptions in which this is not possible without suitable protection:

- permanent moisture
- pH value > 12.5

In such a case, standard corrosion protection coatings can be used.

2.3 Resistance coefficients in accordance with DIN 1988-300

The resistance coefficient for the respective fitting can be read from the following tables. The table is created in the style of DIN 1988-300 Annex A and shows the resistance coefficients of different fittings in different sizes:

No.	Individual resistance ^b	Abbreviations in accordance with DVGW W 575	Graphical symbol ^a , simplified depiction	Resistance coefficient ξ										
				DN 12	DN 15	DN 20	DN 25	DN 32	DN 40	DN 50	DN 65	DN 80	DN 100	
				Pipe outer diameter d_s mm										
				16	20	25	32	40	50	63	75	90	100	
1	T-piece, branching, flow separation	TA		17.2	8.1	5.6	9.3	3.5	3.0	3.1	4.1	3.5	3.5	
2	T-piece, passage, flow separation	TD		6.0	3.6	2.1	4.8	1.1	0.8	0.7	0.8	0.8	0.8	
3	T-piece, counterflow, flow separation	TG		11.5	6.8	5.3	3.7	3.5	3.0	3.1	4.1	4.0	4.0	
4	T-piece, branching, merging flow	TVA		17.0	10.0	8.0	5.0	5.5	4.5	4.0	3.5	3.5	3.5	
5	T-piece, passage, merging flow	TVD		35.0	23.0	16.0	11.0	10.0	9.0	8.0	7.0	6.0	6.0	
6	T-piece, counterflow, merging flow	TVG		27.0	17.0	12.0	9.0	8.0	7.0	6.0	5.0	5.0	5.0	
7	Angle/bend 90°	W90		17.3	7.4	5.7	8.3	3.3	3.0	3.5	4.0	4.0	4.0	
8	Angle/bend 45°	W45		3.0	2.5	2.0	1.5	1.5	1.0	1.0	1.0	1.0	1.5	
9	Reduction	RED		3.1	2.6	2.0	1.0	1.0	1.3	0.3	0.5	0.4	-	
10	Wall panel	WS		8.1	6.6	-	-	-	-	-	-	-	-	-
11	Double wall panel passage	WSD		5.0	4.5	4.0	-	-	-	-	-	-	-	-
12	Double wall panel branching	WSA		4.0	3.5	3.0	-	-	-	-	-	-	-	-
13	Manifold	STV		4.5	3.0	-	-	-	-	-	-	-	-	-
14	Coupling/socket	K		3.1	3.5	2.2	5.0	5.0	0.9	0.9	0.7	0.7	0.7	0.7

3. Processing

3.1 Fitting assembly



Cut the MAINPEX composite pipe to length at a right angle using the corresponding original tool by MAINCOR. Then push the sliding sleeve over the pipe which is not widened yet. Plug the pipe end to the stop on the expansion head to widen the pipe by compressing the expansion caliper to the mechanical stop. Then the pipe has to be moved over the whole fitting profile and the sliding sleeve positioned to the widened pipe end. Afterwards insert the pipe with the fitting into the sliding tool. Take notice of the correct sliding jaws. The sliding procedure is finished as the sleeve is slid on the pipe as far as it will go.

Processing instructions

The MAINPEX System can only be processed with corresponding system tools. For workmanship handtools and also electrically operated tools are available. According to the several dimensions there are suitable sliding tools and expansion heads at hand to be mounted or screwed.

The expansion head has to be chosen relevant to the pipe diameter. Please note that dimension 25 can be widened at most two times. If it is necessary to widen twice the expansion head has to be turned for 30° respectively to the first widening. From dimension 32 widening is possible up to three times. Here it is also necessary to turn the expansion head for 30° after each widening. By turning the expansion head the marks in the inner layer of the pipe are straightened. The widening depth is limited by the expansion head so there will be an annular gap between the end of the pipe and the fitting after pushing the pipe on the fitting.

A further sliding of the pipe onto the fitting (as shown above) is not needed. By sliding the sleeve onto the fitting the pipe is picked and locks the annular gap.

3.2 Bends

In principle, the MAINPEX composite pipe can be bent in compliance with the smallest bending radii. Bending is possible by hand or with a tool. If the pipes are bent by hand, both hands must be used in order to prevent buckling of the pipe bend. The pipes may not be bent directly at the connection.



Flexible springs or benders are approved as auxiliary tools. When bending with the inner flexible spring, the pipe end must firstly be deburred. During the bending procedure, the ribs of the flexible spring may not be visible on the outer coating.

The hot bending of the MAINPEX composite pipe by means of open flames or other heat sources is forbidden. The repeated bending around the same bending point is prohibited. If the minimum bending radius is not met, a corresponding structural piece must be used.

	Bending radius by hand ($5 \times d_a$)	Bending radius using inner flexible spring ($4 \times d_a$)	Bending radius using machine ($4 \times d_a$)
16 x 2.2	80	64	64
20 x 2.8	100	80	80
25 x 3.5	125	100	100
32 x 4.4	-	-	-
40 x 4.0	-	-	-
50 x 4.5	-	-	-

The specified minimum bending radii must not be undershot! If a pipe is buckled or damaged in another way, this must be replaced or a corresponding structural piece must be used.

3.3 Pipe laying and fastening

Pipelines in the floor structure must be planned in such a way that they do not cross. The pipelines should be made as straight as possible, in parallel to the walls and the axes. As a rule, pipeline crossings lead to larger construction heights. This can be avoided by careful planning. Pipe clips and fastening materials for the MAINPEX composite pipe system may only be used if these are suitable for the pipe material and the pipe diameter. Requirements regarding clip protection and length expansion must be considered.

- When fastening, the entire weight of the system during function must be considered. Fastener spacings can be found in the system data overview (see point 2.1).
- Wall and ceiling openings must be executed such that the regulations in the areas of fire protection and sound insulation in buildings are adhered to.
- Direct contact with wall and concrete parts is not permitted.
- Fittings and MAINPEX composite pipe must be protected from external influences such as aggressive media and materials, UV radiation and saline air.
- Depending on the application, the sealing of wall and ceiling openings does not have to be executed in accordance with the regulations for fire protection and sound insulation as well as in accordance with the recognised technical regulations.

Pipes moulded into floor screed or into concrete

Due to the relatively low expansion forces of the pipes, no compensation measures are necessary in the case of direct embedding into concrete or floor screed. Due to the plastic deformability of multi-layer composite pipes, the resulting forces are intercepted by the pipe wall, but the requirements for heat and impact sound insulation must be considered.

Pipes in the floor structure

In that MAINPEX multi-layer composite pipes can move axially within the insulation without great resistance, the expected changes in length must be intercepted at right-angled diversions in the insulation later. Insulated pipelines which are already laid in the floor must be protected from damage during the construction phase. Before completion of the floor structure, it must be checked that insulated pipes which are laid on the floor are not damaged. Damages must be resolved to guarantee heat and sound insulation.

When laying pipes above the floor, the following principles should be considered:

- Lay pipelines thermally insulated and acoustically decoupled
- Avoid pipe crossings as far as possible
- Lay pipelines in parallel to walls
- Pipelines flow into adjacent walls at right angles
- Maximum width of the pipelines 120 mm
- Minimum spacing between pipelines and walls in hallways 200 mm, in living area 500 mm.
- Wrap pipeline though floor screed expansion joints with corrugated tube or alternatively with 6mm pipe insulation (plain bearings).

Pipelines laid under plaster

Pipelines laid under plaster should always be insulated in order to compensate for length expansion forces of the pipes during temperature increase. Damages in the plaster can thereby be avoided. If no heat insulation is required, the composite pipe can be laid in a protective tube. In principle, direct contact with plaster, cement, tile cement, etc. must be avoided by suitable measures.

Freely suspended pipelines and pipelines laid under plaster

Freely suspended pipelines and pipelines laid under plaster must be fastened with pipe clips in accordance with the table under point 2.1 and in accordance with thermal and sound insulation. Thermal changes in length must be taken into account, if necessary, by the arrangement of bending legs in connection with fixed points and plain bearings.

Protection from exterior corrosion

MAINPEX fittings must be protected from external corrosion (which occurs due to moisture and the influence of oxygen, saline air or aggressive ambient materials), if necessary, by corrosion protection coatings.

3.4 Insulation of MAINPEX pipes

Drinking water installation

In order to select the correct insulation layer thickness for the drinking water installation, hot and cold water installations must be differentiated between. In principle, the insulation should act in opposite ways for each application. The insulation in the hot water installation serves to reduce heat losses, whereas the insulation in the cold water installation is used to prevent the undesired introduction of heat into the cold water line and to prevent the formation of condensation.

The requirements for minimum insulation layer thicknesses are regulated in DIN 1988-200, as well as in the EnEV (Energy Saving Ordinance) 2014. The insulation layer thicknesses relate to the specified heat conductivity and can be reduced if the same limit of heat dissipation can also be ensured with other types of insulation.

Drinking water - cold			Drinking water - hot		
No.	Installation situation	Insulation layer thickness 0.040 W/(m x K) ^a	No.	Installation situation	Insulation layer thickness 0.035 W/(m x K)
1	Pipelines laid freely in non-heated rooms, ambient temperature < 20°C (only condensation protection)	9 mm	1	Inner diameter up to 22mm	20 mm
2	Pipelines laid in pipe shafts, floor channels and suspended ceilings, ambient temperature ≤ 25°C	13 mm	2	Inner diameter greater 22mm to 35mm	30 mm
3	Pipelines laid, for example in technology centres or media channels and shafts during heat loads and ambient temperatures ≥ 25°C	Insulation such as hot water pipeline	3	Inner diameter greater 35mm to 100mm	Gleich Innendurchmesser
4	Multi-storey pipelines and individual supply lines in pre-wall installations	Pipe-in-pipe or 4mm	4	Inner diameter greater 100mm	100 mm
5	Multi-storey pipelines and individual supply lines in the floor structure (also in addition to non-circulating drinking water pipelines hot) ^b	Pipe-in-pipe or 4mm	5	Pipelines and fittings according to installation situation 1 to 4 in wall and ceiling openings, in crossing regions of pipelines, at pipeline connection points, at central pipeline network distributors	Half of the requirements for installation situation 1 to 4
6	Multi-storey pipelines and individual supply lines in the floor structure in addition to hot circulating pipelines ^b	13 mm	6	Drinking water pipelines hot, which are neither integrated into the circulation circuit nor are designed with a heating cable, for example multi-storey or individual supply lines with a water content < 3%	No insulation requirements against heat dissipation ^b

^a The insulation layer thicknesses must be converted accordingly for other thermal conductivities; Reference temperature for the specified thermal conductivity: 10°C.

^b In connection with underfloor heating, the pipelines for drinking water cold must be laid such that the requirements in accordance with §3.6 DIN1988-200 are adhered to.

^a The insulation layer thicknesses must be converted accordingly for other thermal conductivities; Reference temperature for the specified thermal conductivity: 40°C.

^b Insulation is required for laying under plaster (for example pipe-in-pipe or 4mm as mechanical protection or corrosion protection).

Heating installation

Heating pipelines must be insulated against heat loss just as hot drinking water pipelines. The table across from this explains which insulation layer thickness is required in accordance with the EnEV (Energy Saving Ordinance) 2014. As far as in the cases of §14 Paragraph 5, heat distribution and hot water pipelines border on ambient air, these must be insulated with double the minimum thickness in accordance with Table 1, Lines 1 to 4.

Pipeline insulation in accordance with EnEV (Energy Saving Ordinance)		
No.	Installation situation	Insulation layer thickness 0.035 W/(m x K)
1	Inner diameter up to 22mm	20 mm
2	Inner diameter greater 22mm to 35mm	30 mm
3	Inner diameter greater 35mm to 100mm	Same inner diameter
4	Inner diameter greater 100mm	100 mm
5	Pipelines and fittings according to installation situation 1 to 4 in wall and ceiling openings, in crossing regions of pipelines, at line connection points, at central pipeline network distributors	Half of the requirements for installation situation 1 to 4
6	Heat distribution pipelines according to installation situations 1 to 4, which are laid in components between heated rooms of different users after 31 January 2002	Half of the requirements for installation situation 1 to 4
7	Pipelines according to installation situation 6 in the floor structure	6 mm
8	Cold distribution and cold water pipelines as well as fittings for ventilation technology and air conditioning systems	6 mm

The insulation requirements which are set in the EnEV (Energy Saving Ordinance) 2014 and were explained in the table above are more or less complex. In practice, the following table is vital for daily use.

Use	Multi-family house / non-residential building several users	Single-family house / non-residential building 1 user
Pipelines in unheated rooms and cellar rooms	100%	100%
Pipelines in outer walls, outer components, between an unheated and heated room, in shafts and channels	100%	100%
Distribution lines for the supply of several different users	100%	No requirement
Pipelines laid in the floor, also radiator connection lines against the ground / unheated rooms ¹⁾	100%	100%
Pipelines and fittings in wall and ceiling openings, in the crossing region of pipelines, at pipeline connection points, at central pipeline distributors	50%	50%
Pipelines in components between heated rooms of different users	50%	No requirement
Pipelines laid in the floor structure, between heated rooms of different users	see EnEV (Energy Saving Ordinance), Tab. 1, Annex 5, Line 7 ²⁾	No requirement
Heating lines in heated rooms or in components between heated rooms of one user and capable of being shut off	/	No requirement

¹⁾ Eccentric/asymmetrical pipe tubing is admissible for limiting heat dissipation. The nominal thickness must be arranged towards the cold side. Details can be gleaned from the necessary General Building Supervisory Approval (ABZ) of the respective manufacturer.

²⁾ Although no requirements are stated here, it must be insulated due to corrosion protection, cracking and flowing noises, structure-borne insulation as well as reduction of the thermal load.

As the insulation layer thickness can be reduced if the same limit of heat dissipation is ensured, we have created a comparative table. This shows the dependency of thermal conductivity and pipe dimension with respect to the insulation layer thickness.

Minimum thickness of the insulation layer for pipe 100%
(EnEV (Energy Saving Ordinance) 2014, Annex 5, Table 1)

Pipe dimensions						
Thermal conductivity	16 x 2.0	20 x 2.25	25 x 2.5	32 x 3.0	40 x 4.0	50 x 4.5
0.025	11	11	12	17	18	24
0.030	15	15	16	23	24	32
0.035	20	20	20	30	30	41
0.040	26	26	25	38	38	51
0.050	44	41	39	59	57	77

Minimum thickness of the insulation layer for pipe 50%
(EnEV (Energy Saving Ordinance) 2014, Annex 5, Table 1)

Pipe dimensions						
Thermal conductivity	16 x 2.0	20 x 2.25	25 x 2.5	32 x 3.0	40 x 4.0	50 x 4.5
0.025	6	6	6	9	9	13
0.030	8	8	8	12	12	17
0.035	10	10	10	15	15	21
0.040	13	13	12	18	18	25
0.050	20	19	18	27	26	36

3.5 Fire protection

Fire protection is everywhere in daily life. For this reason, there are numerous laws and guidelines as well as corresponding regulations. The fundamental regulation is located in the Model Building Code of the Bauministerkonferenz (Conference of the Ministers of Construction) in the version of November 2002. Here, §14 defines what is to be understood exactly by fire protection.

§14 MODEL BUILDING CODE

Structural systems must be arranged, established, changed and maintained such that the development of a fire and the spreading of fire and smoke (spread of fire) is prevented and, during a fire, the escape of people and animals as well as effective extinguishing work are possible.

The subject of fire protection concerns everyone. Both the planner and the processor must be informed about the applicable standards and laws of the Bundesländer (Federal States).

For pipeline systems, installation shafts and channels, §40 of the Model Building Code states:

1. Pipelines may only be inserted through room-separating components for which a fire resistance capability is prescribed, if a spread of fire is not to be feared for a sufficiently long time or provisions are made against this. This does not apply:
 - for buildings of building classes 1 and 2
 - within flats
 - within the same utilisation unit with no more than a total of 400 m² on no more than two levels
2. Pipeline systems are only admissible in required staircases, in spaces in accordance with §35 Paragraph 3 Sentence 2 and in required halls if a use as an escape route in the case of fire is possible for a sufficiently long time.
3. For installation shafts and channels, Paragraph 1 as well as §41 Paragraph 2 Sentence 1 and Paragraph 3 apply accordingly.

In accordance with §40, the arrangement of the pipelines must correspond to the MLAR/LAR/RbALei (Model Pipeline System Guidelines/Pipeline System Guidelines/Guideline for Fire Protection Requirements for Pipeline Systems). The selection of the building material is very important in order to ensure preventive fire protection. DIN 4102 regulates this. The planning and assembly aid for pipeline systems by the company, Rockwool, is adapted to the subject to be correspondingly large. The extract of the planning and assembly aid is located on the next page, which describes the MAINCOR pipes in connection with fire protection.

In buildings in which fire protection requirements exist, supply lines may only then be passed through walls, ceilings, etc., if it is ensured that a transfer of fire and smoke is not to be feared or precautions are taken against this. Fire protection openings must be approved and checked. Such openings are pipe openings made from a specific insulating material, or fire protection collars which swell with heat input and which seal the opening to be resistant against fire and smoke.

In principle, the provisions from DIN 4102 Fire protection in building construction and the corresponding Federal Building Codes must be considered. Furthermore, procedures are proposed in the MLAR (Model Pipeline System Guidelines). For the MAINPEX installation pipe system, a pipe opening by Rockwool is used in order to implement a fire protection solution.

3.4 Plastic / multilayer composite pipe

R 30 - to R 90 pipe opening for the MAINCOR installation system for non-flammable media e.g. potable water, heating

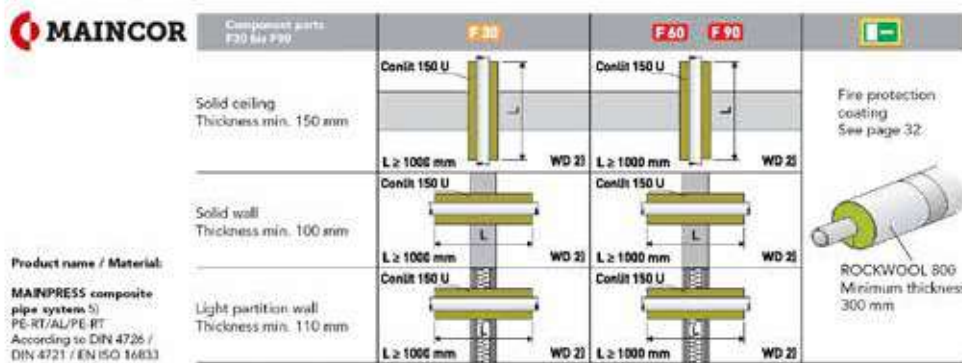

Design variants in accordance with ROCKWOOL abF P-3226/4140-MPA BS
 Further instructions for planning/assembly, see chapter 2

System	Pipe dimension	Conilit 150 U			ROCKWOOL 800 (1) (2) (3)		
		Type 3)	Insulation thickness 4)	Core drilling Dk [mm]	EnEV 100 % Warm, Type	EnEV 50 % Warm, Type	DIN 1988-200 Cold Type 3)
MAINPRESS Composite pipe system	16,0	16/22	22,0	60	18/20	18/20	18/20
	20,0	20/20	20,0	60	22/20	22/20	22/20
	25,0	25/17,5	17,5	60	28/20	28/20	28/20
	32,0	32/24	24,0	80	35/30	35/20	35/30
	40,0	40/20	20,0	80	42/40	42/20	42/40
	50,0	50/25	25,0	100	54/40	54/30	54/40
MAINPEX Sliding sleeve system	16,0	16/22	22,0	60	18/20	18/20	18/20
	20,0	20/20	20,0	60	22/20	22/20	22/20
	25,0	25/17,5	17,5	60	28/20	28/20	28/20
	32,0	32/24	24,0	80	35/30	35/20	35/30
	40,0	40/20	20,0	80	42/40	42/20	42/40
	50,0	50/25	25,0	100	54/40	54/30	54/40

Instructions/Special installation requirements

- 1) In some cases the deliverable minimum insulation thickness is specified
- 2) As further insulation, the insulation shell ROCKWOOL 800 can be used
- 3) With cold pipes a vapour barrier must be used according to DIN 1988-200, therefore, exclusively use fire protection coating Conilit 150 U / 800 ROCKWOOL insulating shell
- 4) Insulation thickness according to DIN 1988-200 EnEV 50% and suited to the core-drilling diameter Dk
- 5) Coatings such as condalite or factory insulation must be removed in the area of feed through

All requirements of the specified general building inspector certificate (abF) must be followed.

See: http://download.rockwool.de/media/300973/br_pm_rohrleitungsanlagen.pdf

3.6 Sound insulation

DIN 4109 regulates the requirements for protection against airborne and impact sound transfer between external living and work spaces as well as from structurally connected facilities, against noises from domestic systems and against outside noise. The maximum installation noise level L_{in} in housing of $\leq 30\text{dB(A)}$ at the moment corresponds to the recognized rules of engineering as well as the current jurisdiction. An extended sound insulation per working contract can be agreed over DIN 4109 in accordance with VDI 4100. The classification of the sound insulation steps in VDI 4100 is similar to those of DIN 4109. However, additionally, many useful notes for sound insulation planning can be found in the VDI guidelines 4100.

Supplementary table A1 from DIN 4109

Noise source	Type of rooms in need of protection	
	Living rooms and bedrooms	Teaching and work rooms
Water installations (water supply and waste water systems)	$\leq 30\text{ dB(A)}$	$\leq 35\text{ dB(A)}$
Other domestic systems	$\leq 30\text{ dB(A)}$	$\leq 35\text{ dB(A)}$
Facilities day 6am to 10pm	$\leq 35\text{ dB(A)}$	$\leq 35\text{ dB(A)}$
Facilities night 10pm to 6am	$\leq 25\text{ dB(A)}$	$\leq 35\text{ dB(A)}$
a) Individual short-term peaks which result during confirmation of the fittings and devices according to Table 6 (opening, closing, changing, interrupting, etc.), are not able to be considered at this time.		
b) Work contract requirements for the fulfilment of the admissible installation sound pressure level: <ul style="list-style-type: none"> The execution documents must consider the requirements of sound insulation, i.e. among other things, the required sound insulation certificates must be present for the components Furthermore, the responsible construction management must be named and must be consulted for participation before sealing or covering the installation. The ZVSHK data sheet regulates further details. (Can be obtained from: Central Association Plumbing, Heating and Air Conditioning (ZVSHK), Rathausallee 6, 53757 Sankt Augustin) 		
c) Values which are higher by 5 dB(A) are admissible for ventilation systems, as long as they are prolonged noises without striking individual tones.		

In principle, with the following simple measures, structure-borne sound transfer can be prevented in drinking and waste water systems:

- The coating of the installation pipes with sound-absorbing materials (e.g. normal insulation) for pipe openings through walls or ceilings
- Sufficient dimensioning of the pipes in order to prevent flow noises
- Use sound insulation inserts (e.g. rubber) in fastening clips, wall brackets, devices as well as furnishings.

It is important that a written agreement with the respective other party is made concerning the required sound insulation level. DIN 4109 represents the recognised rules of engineering which must be adhered to according to building regulations.

Jörg Schütz, Director of Technology Trade Association of Plumbing, Heating and Air Conditioning Technology, Bavaria, member of the regulation committee for DIN 4109 and VDI 4100, has written a very good treatise on this topic:

<http://www.ikz.de/nc/sanitaer/news/article/schallschutzwerte-rechtssicher-vereinbaren-0051517.html>

3.7 General laying guidelines

All MAINPEX system components are well protected in the original packing. Therefore, all components (fittings and pipes) should be protected from mechanical damage/impairment and that caused by weather conditions. For reasons of hygiene, surfaces in contact with water must be provided with end caps.

Impairment by UV radiation

MAINPEX multi-layer composite pipes must be protected from direct, intense solar radiation and ultraviolet (UV) radiation. This relates both to the storage of the pipes and to completed system parts. They should therefore not be stored unprotected in the open. Completed systems or system parts must be protected with suitable measures against the effect of UV radiation.

Potential equalisation

VDI 0190, Parts 410 and 540 call for a potential equalisation between the protective conductors and the „conductive“ water, waste water and heating pipes. The MAINPEX installation pipe systems do not constitute conductive pipe systems and cannot be used for potential equalisation. Therefore, they also do not need to be earthed. The potential equalisation occurs directly at the potential equalisation rail at the position provided in the plan in accordance with the corresponding VDE guidelines of the components to be earthed. It must be checked by an approved electrician that the installation does not impair the electrical protection and earthing measures which are present (see for this purpose VOB (Construction Contract Procedures), Part C, ATV (General Technical Contractual Conditions)).

Processing temperature

The processing temperature for the MAINPEX installation pipe system should not fall below -10°C.

Frost protection

When using MAINPEX installation pipe systems in pipe networks which are protected from frost, MAINCOR recommends the use of ethylene glycol. This can be used up to a maximum concentration of 35%. This concentration corresponds to a frost protection of approximately -20°C. Before using alternative frost protection sets, approval should be requested from the manufacturer.

Sealing

The manufacture of a threaded connection must occur in accordance with DIN 30660. We recommend the use of hemp in connection with an approved sealing paste (e.g. Fermit). Only so much hemp should be applied so that the thread tips can still be seen. In the case that too large a quantity of hemp is used, there is a risk of damage to the inner thread. By sealing with hemp shortly after the first thread, screwing in at an angle is avoided. Other sealants can be used as an alternative to hemp (e.g.: sealing chord, sealing tape, etc.) in accordance with the manufacturer's specifications.

In order to prevent an impairment of the MAINPEX installation system, contact with materials containing solvents (e.g.: foam, paints, sprays, glues, etc.) must be prevented.

Tips and notes

Our employees are readily available to help you during planning. Contact your responsible sales representative.

Approximate assembly times

MAINPEX Mehrschichtverbundrohr (mm)	Nennweiten	Montagezeiten für laufende Meter (Fertig verlegt inkl. Befestigung in Gruppenminuten)
16	DN 12	4 - 8 min
20	DN 15	5 - 9 min
25	DN 20	6 - 10 min
32	DN 25	7 - 11 min
40	DN 32	13 - 15 min
50	DN 40	15 - 17 min

The specified assembly times are absolute approximate values in group minutes. calculation for fitters with system experience .

All other secondary services are not included.

Hot water tank

The possible temperature limit of the MAINPEX composite pipes may not be exceeded in normal operation and during breakdown. This applies in particular for the use of solar storage tanks or direct fired hot water tanks. Maximum hot water output temperatures must be checked during start-up or must be requested from the respective manufacturer or supplier.

Instantaneous water heaters

Inadmissibly high temperatures and pressures can result during use of instantaneous water heaters. In order to prevent damage to the MAINPEX composite pipe system, device manufacturer specifications must be considered across the board.

Fittings

The assembly of fitting connections must occur so that they are fundamentally non-rotatable.

Moisture protection

DIN 18195-5 regulates the required moisture protection in sanitary facilities. For domestic bathrooms with moisture-sensitive perimeter components, the protection against moisture must be considered during planning. Because of the frequent use of plaster building materials and wood materials in the bathroom, it is strongly recommended to execute moisture protection measures. This applies in particular for fitting connections „under plaster“ as well as for openings in plaster for bathtubs and showers.

3.8 Heating installations with MAINPEX

Requirements for the dimensioning of a pump hot water heating system:

- Enter radiators and heat outputs in floor plan / pipeline system plan
- Define pipe layout exactly
- Number individual sections from the heat generators to the radiators
- Enter respective heat outputs and pipe lengths in the pipeline system diagram

Typical values for an estimated dimensioning of the pipelines:

Installation location	Estimated MAINPEX pipe
Radiator connection lines	16 x 2.2
Risers for 2-3 radiators	20 x 2.8 to 25 x 3.5
Riser and horizontal distribution from 5 radiators	25 x 3.5 to 32 x 4.4

Regulation of the system

In accordance with VOB/C (Construction Contract Procedures) - DIN 18380, hydraulic compensation must be implemented. The compensation ensures that all heat consumers (radiators) are supplied according to their heat requirement or become warm evenly. A final adjustment of regulation values (e.g. flow temperature, heating curve) occurs at the end of the first heating period or after completion of the building. For the proper maintenance of pressure, the form of the membrane expansion tank must be adjusted correctly.

Decrease

- Complete testing of the system
- Compliance with technical or official regulations
- Functional testing within the framework of a trial operation

Instruction concerning transfer

- Occurs through the system creator
- Comprises the presentation of test certificates, maintenance and operating manuals

Maintenance

For heating systems which require qualified operating personnel, operating and maintenance manuals must be created in accordance with DIN 12170.

General

Our employees are readily available to answer any questions you may have. Please contact the technical department or the responsible sales representative. Additionally, MAINCOR clients have the opportunity to use free-of-charge programmes for the estimated calculation of heating, sanitation and ventilation systems via our homepage by means of their client number and a self-selected password.

The information and technical data contained in the manuals, catalogues and other written documents such as, for example, drawings and plans, must be checked by the buyer before acceptance and use. The buyer cannot derive any claims against MAINCOR or its employees from these documents and additional services, unless these have acted in an intentionally or grossly negligent manner. MAINCOR reserves the right to carry out changes to its products, even to those which have already been commissioned, without prior notice, within appropriate and reasonable limits.

Pipe performance data

Spread	10 K	15 K	20 K	m	R	w
Pipe dimensions	max. Heizleistung Q [KW]			[kg/h]	[Pa/m]	[m/s]
16 x 2.2	1.20	1.90	2.50	104.00	99.00	0.25
20 x 2.8	2.50	4.00	5.00	233.00	111.00	0.33
25 x 3.5	5.00	7.50	10.00	434.00	105.00	0.39
32 x 4.4	10.00	16.00	20.00	866.00	100.00	0.46
40 x 4.0	18.00	27.50	37.50	1612.00	109.00	0.56
50 x 4.5	3.00	52.50	70.00	3009.00	101.00	0.64

Recommended maximum pressure losses:

Heating systems: 100 - 200 Pa/m

Underfloor heating systems: 100 - 200 Pa/m

Recommended maximum flow velocities:

Radiator connection lines: up to 0.5m/s

Heat distribution lines: up to 1.0m/s

3.9 Sanitary installations with MAINPEX

Essential planning foundations

- DIN 1988 - 100 / 200 / 300
- DIN EN 1717
- VDI 6029
- DIN EN 806
- Floor plans and building sections of the object
- Specifications - water heating
- Pipe material
- Available water supply pressure (information on the water supplier)

General requirements for drinking water heating systems (TWEA)

- Continuous availability of hot water requirement
- Hot water withdrawal without delay
- Simple operation
- Careful planning and assembly
- High operational safety
- Faultless operation in terms of hygiene
- Compliance with standards and regulations
- Precise dimensioning corresponding to use
- Use-orientated calculation of the hot water costs

Source: Claus Ihle, Rolf Bader, Manfred Golla; „Tabellenbuch Sanitär/Heizung/Klima/Lüftung-Anlagentechnik, Ausbildung und Praxis“ (Data manual for plumbing/heating/air conditioning and ventilation technology, training and practice); 6th edition, Bildungsverlag EINS GmbH, Troisdorf 2007

Dimensioning - planning foundations:

Drinking water is subject to the strictest legal hygiene requirements. With regard to professional dimensioning, this means that drinking water may not protrude into pipelines which are too generously dimensioned. Drinking water pipeline networks must be planned, dimensioned and laid in accordance with DIN 1988 - 100 / 200 / 300. Differentiated bases for calculation of the pipe diameter, maximum flow velocities as well as flow rate, connection and use values are regulated in DIN 1988-300.

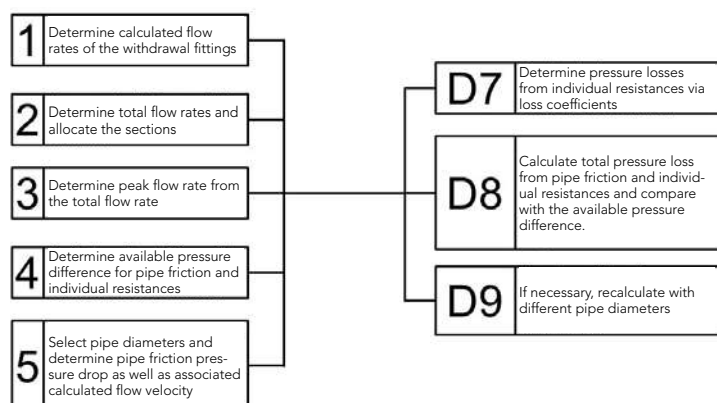

Maximum calculated flow velocity DIN 1988-300

**Maximum calculated flow velocity for
flow duration in m/s**

Performance phase	< 15 min	> 15 min
House connection line	2.0	2.0
Consumption lines: Sections with resistance coefficients <2.5 for the individual resistances ^{a)}	5.0	2.0
Consumption lines: Sections with resistance coefficients ≥ 2.5 for the individual resistances ^{b)}	2.5	2.0

^{a)} for example, piston valve, ball valve, angle seat valve

^{b)} for example straight seat valve

Withdrawal location	DN	Flow pressure	Temperature	Flow rate		Only cold or hot water
		P_{MF} in mBar	°C	V_{RKW} (l/s)	V_{RWW} (l/s)	R (l/s)
Discharge valve	15	500	-	-	-	0.3
Without air mixer	20	500	-	-	-	0.5
	25	500	-	-	-	1.0
Shower head	15	1000	38	0.15	0.15	-
Bathtub system, mixer tap	15	1000	40	0.15	0.15	-
	20	1000	40	0.5	0.5	-
Lavatory system, flush valve	15	1200	10	0.7	-	-
	20	1200	10	1.0	-	-
Cistern	15	500	10	0.13	-	-
Mixer tap	15	1000	50-55	0.07	0.07	-
	20	1000	50-55	0.3	0.3	-
Kitchen sinks, discharge valve	15	500	10	0.07	-	-
Row of washbasins, mixing valve	15	1000	35	0.07	0.07	-
Shower mixer	15	1000	38	0.15	0.15	-
Dishwasher	15	500	10	0.07	-	-
Washing machine	15	1000	10	0.15	-	-
Instantaneous water heater, electronically controlled	15	500	30-55	0.17	-	-
Gas / flow rate Multi-purpose water heater	Without pressure losses in safety or connection fittings of downstream pipelines and withdrawal fittings					
Q _{NL} 8.7 kW	15	800	30-60	0.07	-	-
Q _{NL} 17.4 kW	15	800	30-60	0.16	-	-
Q _{NL} 22.7 kW	15	1300	30-60	0.21	-	-
Q _{NL} 27.9 kW	15	1700	30-60	0.26	-	-

4. Drinking water supply

4.1 Drinking water

Drinking water is not usually sterile and may contain a certain amount of bacteria which has, according to experience, no effects on human health. Drinking water is any water which is specified for drinking, cooking, preparing food and drink or for the following domestic purposes:



- Personal hygiene
- Cleaning of objects which are intended to come into contact with food products
- Cleaning of objects which are intended to come into contact with the human body on more than a temporary basis

In accordance with the Drinking Water Ordinance (TrinkwV), water must fulfil the following requirements to be drinking water:

- colourless
- odourless
- free of pathogens
- having a content of dissolved mineral materials in specific concentrations
- neutral and cool in taste
- not damaging to health

Drinking water must be created such that damage to human health, in particular by pathogens, is not to be feared due to its consumption or use. It must be pure and fit for consumption.

Much has changed in drinking water distribution. Until recently, exclusively the water suppliers were obliged to supply perfect drinking water quality. To comply with this requirement, the water suppliers were only responsible for the quality until the transfer point of the water. The withdrawal location of the user, however, is usually not at the transfer location, but within the domestic installation. In accordance with the amendment to the Drinking Water Ordinance in December 2012, planners, installers and operators are now jointly responsible for providing the user with the best quality drinking water. The Federal Environment Agency defines this rather well: „Its the last few metres that count!“

4.2 Drinking water distribution

The relevant regulations, standards and directives such as DIN 1988, TrinkwV (Drinking Water Ordinance) etc. prioritise the hygienic protection of the drinking water. Therein, the water is defined at the consumption location in the form of limit values which can be checked accordingly at withdrawal locations or by means of special sampling fittings (this must also take place in the case of industrial use).

The responsibility for the use of the system as intended (temperature specifications) is incumbent upon the operator. The suitability of the system for the intended operation, so the compliance with limit values, is the responsibility of the planner or of the planning installer. I.e. the installation should be executed such that the hygiene risk is kept as low as possible.

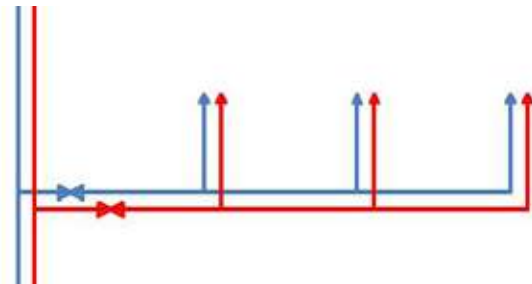

In drinking water distribution, T-piece distribution, series connection with U-shaped wall brackets and closed circular pipelines with U-shaped wall brackets are differentiated between. For reasons of hygiene, the „classic“ T-piece distribution should only be used at consumption locations which are used regularly and daily. A minimum hygiene risk cannot be ruled out as stagnating water remains in the short supply lines to the consumers.

In the case of the series connection with U-shaped wall brackets, stagnant water in the supply lines to the individual consumers is prevented. Therein, the mostly frequently used consumer should be installed at the end of the series. If the withdrawal location with the largest consumption is positioned at the beginning of the series, then a lower pressure loss is achieved than if the largest consumer were at the end of the series.

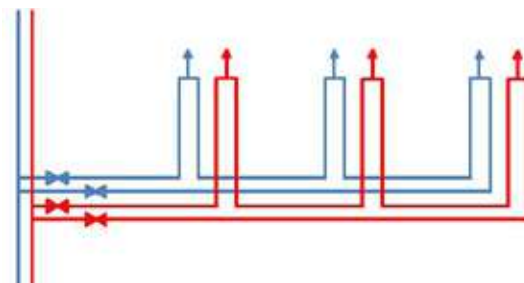

In the closed circular pipeline, a faultless installation in terms of hygiene is ensured as an optimum water exchange always takes place in the pipeline. Because the consumer is supplied from two sides, smaller pipe dimensions can be selected which also supports the water exchange.

In systems with several consumers which are not used regularly, such as, for example: hotels, hospitals, etc., from the point of view of risk minimisation, in fact only the variant of the closed circular pipeline installation with U-shaped wall brackets remains.

5. Rinsing and pressure testing

Pressure and leakage testing as well as rinsing of MAINCOR drinking water installations

in accordance with DIN EN 806-4 and ZVSHK data sheet „Leakage testing of drinking water installations with compressed air, inert gas or water“.



The pressure and leakage testing in accordance with DIN EN 806-4 or in accordance with the ZVSHK data sheet „Leakage testing of drinking water installations with compressed air, inert gas or water“ for the Maincor drinking water pipe systems, MAINPRESS, MAINPEX and MAIN-OX, must be implemented after the completion of the installation.

All components of the installation must be freely accessible and visible. If a regular water exchange is not ensured at the latest seven days after the pressure testing, then the implementation of a pressure test with compressed air or inert gas is recommended.

Special note for pressurising with compressed air or inert gases

All pipelines must be closed with metallic stoppers, caps, blanks or blind flanges. Closed shut-off fittings do not count as having been sealed closed. Devices, fittings, pressurised containers or drinking water heaters must be separated from the pipelines before the pressure test. A visual check of all pipe connections for professional execution was carried out. Leak detection spray can be used for leak detection.

Reports and certificates are to be supplied concerning the implementation of the pressure or leakage testing.

Pressure testing with compressed air or inert gas

Pressure testing with compressed air or inert gases (ZVSHK data sheet „Leakage testing of drinking water installations with compressed air, inert gas or water“)

Exclusively devices must be used, the measurement accuracy of which is +/- 1 mbar. During the test(s), the pressure at the pressure gauge must be monitored continuously.

After a visual test of all connection points, the leakage testing is to be implemented as follows:

Testing pressure: 150 mbar
Testing time: 120 minutes for systems with a volume of up to 100 litres
(+20 minutes per 100 litres of additional volume)

The connectors must be checked for leakages.

In connection to this, the load testing occurs as follows:

Increase of the testing pressure to 3 bar (1 bar for dimensions > 63 mm),
testing time at least 10 minutes

The connectors must be checked for leakages.

A report concerning the leakage testing must be produced in which the impermeability of the system is documented and confirmed.

Testing report for MAINCOR drinking water installations

Pressure testing medium: oil-free compressed air nitrogen carbon dioxide _____

Construction project: _____

Construction phase: _____

Tester / Company: _____

MAINCOR installation system used:

MAINPRESS

MAINPEX

MAINPEX with PE-Xc

MAINOX

Pipeline volume: _____ litres Temperature of testing medium: _____ °C

A visual check of all pipe connections for professional execution was carried out.

LEAKAGE TESTING:

Testing pressure: 150 mbar

Testing time up to 100 litres pipeline volume at least 120 minutes

The testing time must be increased by 20 minutes per additional 100 litres.

Once the temperature level and equilibrium is reached, the testing time begins.

Start: _____ (date, time) Testing pressure: _____ mbar

End: _____ (date, time) Testing pressure: _____ mbar

During the testing time, no pressure drop was determined.

LOAD TESTING:

Testing pressure: Installation pipe $d_a \leq 63\text{mm}$ max. 3 bar, Installation pipe $d_a > 63\text{ mm}$ max. 1 bar.

Testing time up to 100 litres pipeline volume at least 10 minutes.

Once the temperature level and equilibrium is reached, the testing time begins.

Start: _____ (date, time) Testing pressure: _____ bar

End: _____ (date, time) Testing pressure: _____ bar

During the testing time, no pressure drop was determined.

CONFIRMATION OF THE SYSTEM IMPERMEABILITY: No leakages could be determined in the aforementioned system, neither during the leakage testing, nor during the load testing.

(place, date)

(stamp, contractor signature)

(place, date)

(stamp, customer signature)

Pressure testing with water

Pressure testing with water (DIN EN 806-4 or ZVSHK data sheet „Leakage testing of drinking water installations with compressed air, inert gas or water“)

Exclusively devices must be used, the measurement accuracy of which is +/- 0.1 mbar. During the test(s), the pressure at the pressure gauge must be monitored continuously. Exclusively filtered drinking water (particle size <150µm) must be used. The correct ventilation of the system must be ensured during filling. Shut-off elements in front of and behind heat generators and tanks must be closed.

The system is filled with filtered water and ventilated completely. During the testing, a visual check of the pipe connectors must be carried out. The temperature equalisation between ambient temperature and the temperature of the water must be considered after production of the testing pressure by a corresponding waiting time. The testing pressure must be produced again after the waiting time, if necessary.

During use of the **MAINPRESS** drinking water system, first a check of the „unpressed, leaking“ connector must be carried out:

Testing pressure: 3 bar
Testing time: 15 minutes

The connectors must be checked for leakages.

After a visual test of all connection points, the **leakage testing itself** is to be implemented as follows for all MAINCOR systems:

Testing pressure: 11 bar
Testing time: 30 minutes

In the case of the use of the **MAINPEX** drinking water system with pipelines made from PE-Xc, an additional test is required:

Testing pressure: 5.5 bar (adjust by relieving the initial test pressure)
Testing time: 120 minutes

A report concerning the leakage testing must be produced in which the impermeability of the system is documented and confirmed.

Leakage testing report for MAINCOR drinking water installations

Pressure testing with test medium „water“

Construction project: _____

Construction phase: _____

Tester/Company: _____

MAINCOR installation system used:

MAINPRESS

MAINPEX

MAINPEX with PE-Xc

MAINOX

Pipeline volume: _____ litres Temperature of testing medium: _____ °C

A visual check of all pipe connections for professional execution was carried out.

LEAKAGE TESTING PRESSING CONNECTOR:

Testing time: 15 minutes

Testing pressure: 3 bar

Start: _____ (date, time)

Testing pressure: _____ bar

End: _____ (date, time)

Testing pressure: _____ bar

LEAKAGE TESTING:

Testing time: 30 minutes

Testing pressure: 11 bar

Start: _____ (date, time)

Testing pressure: _____ bar

End: _____ (date, time)

Testing pressure: _____ bar

LEAKAGE TESTING FOR PE-Xc-PIPE:

Testing time: 120 minutes

Testing pressure: 5.5 bar

Start: _____ (date, time)

Testing pressure: _____ bar

End: _____ (date, time)

Testing pressure: _____ bar

No pressure drop was determined at the pressure gauge during the testing time

CONFIRMATION OF THE SYSTEM IMPERMEABILITY: No leakages could be determined during the entire testing on the aforementioned system.

(place, date)

(stamp, contractor signature)

(place, date)

(stamp, customer signature)

Rinsing of MAINCOR drinking water installations

For reasons of hygiene, the rinsing should only occur directly before the start-up. Filtered drinking water must be used as a rinsing fluid.

In principle, two rinsing techniques can be applied:

- Rinsing with a water/air mixture in accordance with DIN EN 806-4 should be applied, if a sufficient rinsing effect cannot be expected when rinsing with water. See for this purpose technical rules for drinking water installation DIN EN 806-4 Section 6.2.3.
- The rinsing method with water corresponds to the specifications in the ZVSHK data sheet „Rinsing, disinfecting and start-up of drinking water installations“. More detailed information on the rinsing method with water can be gleaned from these booklets which can be obtained from the Central Association Plumbing Heating Air Conditioning (ZASHK).

A report on the rinsing procedure must be produced in which the proper rinsing of the drinking water system is confirmed.

Rinsing report for MAINCOR drinking water installations

Rinsing medium water

Construction project: _____

Construction phase: _____

Tester/Company: _____

MAINCOR installation system used:

MAINPRESS

MAINPEX

MAINPEX with PE-Xc

MAINOX

Within a storey, the withdrawal locations are fully opened, starting with the withdrawal location which is furthest from the riser.

After a rinsing duration of 5 minutes at the rinsing point which was last to be opened, the withdrawal locations are closed one after the other.

The drinking water used for rinsing is filtered, resting pressure $p_w =$ _____ bar.

Maintenance fittings (shut-off facilities for individual storeys, stop valves) are fully opened.

Sensitive fittings and devices are removed and replaced by fitting pieces or bridged by flexible pipelines.

Aerators, flow limiters are removed.

Built-in dirt-collection sieves and dirt traps in front of fittings were cleaned after rinsing with water.

The rinsing took place in sections according to the rinsing order, starting from the main shut-off fitting, towards the furthest withdrawal location.

CONFIRMATION: The rinsing of the drinking water system has occurred properly.

(place, date)

(contractor signature/stamp)

(place, date)

(customer signature/stamp)

6. Tables

Pipe friction pressure drops

Pipe friction pressure drops depending on peak flow rate (cold water 10°C)

V	16 x 2.2 DN 12		20 x 2.8 DN 15	
	v	R	v	R
l/s	m/s	mbar/m	m/s	mbar/m
0.01	0.1	0.3	0.1	0.1
0.02	0.2	0.6	0.1	0.2
0.03	0.3	1.6	0.2	0.4
0.04	0.4	2.6	0.2	0.9
0.05	0.5	3.8	0.3	1.4
0.06	0.6	5.2	0.4	1.9
0.07	0.7	6.8	0.4	2.4
0.08	0.8	8.5	0.5	3.1
0.09	0.9	10.4	0.6	3.8
0.10	0.9	12.5	0.6	4.5
0.15	1.4	25.3	0.9	9.1
0.20	1.9	41.9	1.2	15.0
0.25	2.4	62.0	1.5	22.1
0.30	2.8	85.4	1.8	30.5
0.35	3.3	112.1	2.1	40.0
0.40	3.8	142.0	2.5	50.6
0.45	4.3	175.0	2.8	62.3
0.50	4.7	211.0	3.1	75.1
0.55	5.2	249.9	3.4	88.9
0.60	5.7	291.8	3.7	103.7
0.65	6.2	336.5	4.0	119.6
0.70	6.6	384.1	4.3	136.4
0.75	7.1	434.5	4.6	154.2
0.80	7.6	487.7	4.9	173.0
0.85			5.2	192.8
0.90			5.5	213.5
0.95			5.8	235.2
1.00			6.1	257.7
1.05			6.4	281.2
1.10			6.8	305.6
1.15			7.1	331.0
1.20			7.4	357.2
1.25			7.7	384.3
1.30			8.0	412.3
1.35			8.3	441.2

25 x 3.5 DN 20			32 x 4.4 DN 25		40 x 4.0 DN 32		50 x 4.5 DN 40	
V	v	R	v	R	v	R	v	R
l/s	m/s	mbar/m	m/s	mbar/m	m/s	mbar/m	m/s	mbar/m
0.10	0.4	1.6	0.2	0.5	0.1	0.1	0.1	0.0
0.20	0.8	5.2	0.5	1.6	0.2	0.3	0.2	0.1
0.30	1.2	10.6	0.7	3.2	0.4	0.7	0.2	0.2
0.40	1.6	17.5	0.9	5.2	0.5	1.1	0.3	0.4
0.50	2.0	25.9	1.2	7.7	0.6	1.7	0.4	0.5
0.60	2.4	35.7	1.4	10.9	0.7	2.3	0.5	0.7
0.70	2.8	47.0	1.7	14.0	0.9	3.0	0.6	0.9
0.80	3.1	59.5	1.9	17.7	1.0	3.8	0.6	1.2
0.90	3.5	73.4	2.1	21.8	1.1	4.7	0.7	1.5
1.00	3.9	88.5	2.4	26.3	1.2	5.7	0.8	1.7
1.10	4.3	104.9	2.6	31.2	1.4	6.7	0.9	2.1
1.20	4.7	122.5	2.8	36.4	1.5	7.8	1.0	2.4
1.30	5.1	141.4	3.1	41.9	1.6	9.0	1.0	2.8
1.40	5.5	161.4	3.3	47.9	1.7	10.3	1.1	3.2
1.50	5.9	182.6	3.5	54.1	1.9	11.6	1.2	3.6
1.60	6.3	205.0	3.8	60.7	2.0	13.0	1.3	4.0
1.70	6.7	228.6	4.0	67.7	2.1	14.5	1.4	4.4
1.80	7.1	253.3	4.3	75.0	2.2	16.1	1.4	4.9
1.90	7.5	279.1	4.5	82.6	2.4	17.7	1.5	5.4
2.00	7.9	306.1	4.7	90.5	2.5	19.4	1.6	5.9
2.10	8.3	334.2	5.0	98.8	2.6	21.2	1.7	6.5
2.20	8.6	363.3	5.2	107.4	2.7	23.0	1.8	7.0
2.30			5.4	116.3	2.9	24.9	1.8	7.6
2.40			5.7	125.5	3.0	26.9	1.9	8.2
2.50			5.9	135.1	3.1	28.9	2.0	8.8
2.60			6.2	144.9	3.2	31.0	2.1	9.5
2.70			6.4	155.1	3.4	33.2	2.1	10.1
2.80			6.6	165.6	3.5	35.4	2.2	10.8
2.90			6.9	176.4	3.6	37.7	2.3	11.5
3.00			7.1	187.5	3.7	40.0	2.4	12.2
3.50			8.3	247.5	4.4	52.8	2.8	16.1
4.00					5.0	67.1	3.2	20.4
4.50					5.6	83.0	3.6	25.2
5.00					6.2	100.3	4.0	30.5
5.50					6.8	119.1	4.4	36.2
6.00					7.5	139.4	4.8	42.3
6.50							5.2	48.9
7.00							5.6	55.9
7.50							6.0	63.3
8.00							6.4	71.1
8.50							6.8	79.4
9.00							7.2	88.0

Pipe friction pressure drops

Pipe friction pressure drops depending on peak flow rate (warm water 60°C)

V	16 x 2.2 DN 12		20 x 2.8 DN 15	
	v	R	v	R
l/s	m/s	mbar/m	m/s	mbar/m
0.01	0.1	0.1	0.1	0.0
0.02	0.2	0.6	0.1	0.2
0.03	0.3	1.2	0.2	0.4
0.04	0.4	2.7	0.2	0.7
0.05	0.5	2.8	0.3	1.0
0.06	0.6	3.9	0.4	1.4
0.07	0.7	5.1	0.4	1.8
0.08	0.8	6.4	0.5	2.3
0.09	0.9	7.9	0.6	2.8
0.10	0.9	9.5	0.6	3.4
0.15	1.4	19.5	0.9	7.0
0.20	1.9	32.5	1.2	11.6
0.25	2.4	48.4	1.5	17.2
0.30	2.8	67.0	1.8	23.8
0.35	3.3	88.3	2.1	31.3
0.40	3.8	112.2	2.5	39.7
0.45	4.3	138.7	2.8	49.1
0.50	4.7	167.7	3.1	59.3
0.55	5.2	199.2	3.4	70.4
0.60	5.7	233.1	3.7	82.3
0.65	6.2	269.4	4.0	95.0
0.70	6.6	308.0	4.3	108.6
0.75	7.1	349.1	4.6	123.0
0.80	7.6	392.5	4.9	138.3
0.85			5.2	154.3
0.90			5.5	171.1
0.95			5.8	188.7
1.00			6.1	207.1
1.05			6.4	226.3
1.10			6.8	246.2
1.15			7.1	266.9
1.20			7.4	288.4
1.25			7.7	310.6
1.30			8.0	333.6
1.35			8.3	357.3

- Vs Peak flow rate in litres/second in accordance with DIN 1988-300
v Flow velocity in metres/second
R Pipe friction pressure drops in millibars/metre (1 mbar = 1 hPa)

25 x 3.5 DN 20			32 x 4.4 DN 25		40 x 4.0 DN 32		50 x 4.5 DN 40	
V	v	R	v	R	v	R	v	R
l/s	m/s	mbar/m	m/s	mbar/m	m/s	mbar/m	m/s	mbar/m
0.10	0.4	1.2	0.2	0.4	0.1	0.1	0.1	0.0
0.20	0.8	4.0	0.5	1.2	0.2	0.3	0.2	0.1
0.30	1.2	8.2	0.7	2.4	0.4	0.5	0.2	0.2
0.40	1.6	13.6	0.9	4.1	0.5	0.9	0.3	0.3
0.50	2.0	20.3	1.2	6.0	0.6	1.3	0.4	0.4
0.60	2.4	28.2	1.4	8.3	0.7	1.8	0.5	0.5
0.70	2.8	37.1	1.7	11.0	0.9	2.4	0.6	0.7
0.80	3.1	47.2	1.9	14.0	1.0	3.0	0.6	0.9
0.90	3.5	58.4	2.1	17.2	1.1	3.7	0.7	1.1
1.00	3.9	70.6	2.4	20.8	1.2	4.5	0.8	1.4
1.10	4.3	83.9	2.6	24.7	1.4	5.3	0.9	1.6
1.20	4.7	98.2	2.8	28.9	1.5	6.2	1.0	1.9
1.30	5.1	113.5	3.1	33.4	1.6	7.1	1.0	2.2
1.40	5.5	129.9	3.3	38.2	1.7	8.2	1.1	2.5
1.50	5.9	147.2	3.5	43.3	1.9	9.2	1.2	2.8
1.60	6.3	165.5	3.8	48.7	2.0	10.4	1.3	3.2
1.70	6.7	184.8	4.0	54.3	2.1	11.6	1.4	3.5
1.80	7.1	205.0	4.3	60.2	2.2	12.8	1.4	3.9
1.90	7.5	226.3	4.5	66.4	2.4	14.1	1.5	4.3
2.00	7.9	248.4	4.7	72.9	2.5	15.5	1.6	4.7
2.10	8.3	271.6	5.0	79.7	2.6	16.9	1.7	5.1
2.20	8.6	295.6	5.2	86.7	2.7	18.4	1.8	5.6
2.30			5.4	94.0	2.9	19.9	1.8	6.1
2.40			5.7	101.5	3.0	21.5	1.9	6.5
2.50			5.9	109.4	3.1	23.2	2.0	7.0
2.60			6.2	117.5	3.2	24.9	2.1	7.6
2.70			6.4	125.8	3.4	26.7	2.1	8.1
2.80			6.6	134.4	3.5	28.5	2.2	8.6
2.90			6.9	143.3	3.6	30.3	2.3	9.2
3.00			7.1	152.4	3.7	32.3	2.4	9.8
3.50			8.3	202.0	4.4	42.7	2.8	12.9
4.00					5.0	54.4	3.2	16.5
4.50					5.6	67.4	3.6	20.4
5.00					6.2	81.7	4.0	24.7
5.50					6.8	97.3	4.4	29.4
6.00					7.5	114.3	4.8	34.4
6.50							5.2	39.8
7.00							5.6	45.6
7.50							6.0	51.7
8.00							6.4	58.1
8.50							6.8	65.0
9.00							7.2	72.1

Vs Peak flow rate in litres/second in accordance with DIN 1988-300

v Flow velocity in metres/second

R Pipe friction pressure drops in millibars/metre (1 mbar = 1 hPa)

MAINPEX pipe friction resistance depending on Q and a spread of 5 k (50°C / 55°C)

**16 x 2.2
DN 12**

Q	m	v	R
W	kg/h	m/s	Pa/m
400	69	0.18	54
600	103	0.28	109
800	138	0.37	178
1000	172	0.46	263
1200	207	0.55	361
1400	241	0.64	472
1600	275	0.74	597
1800	310	0.83	734
2000	344	0.92	883
2200	379	1.01	1045
2400	413	1.10	1218
2600	447	1.20	1403
2800	482	1.29	1599
3000	516	1.38	1807
3200	551	1.47	2026
3400	585	1.56	2256
3600	620	1.66	2497
3800	654	1.75	2749
4000	688	1.84	3011
4200	723	1.93	3284
4400	757	2.02	3568
4600	792	2.12	3862
4800	826	2.21	4166
5000	860	2.30	4480
5400	929	2.48	5140
5800	998	2.67	5840
6200	1067	2.85	6580
6800	1170	3.13	7764
7400	1273	3.40	9035
8000	1377	3.68	10392
8800	1514	4.05	12334

**20 x 2.8
DN 14**

Q	m	v	R
W	kg/h	m/s	Pa/m
1000	172	0.30	94
2000	344	0.60	316
3000	516	0.90	644
4000	688	1.20	1071
5000	860	1.50	1592
6000	1033	1.80	2202
7000	1205	2.10	2899
8000	1377	2.40	3681
9000	1549	2.70	4545
10000	1721	3.00	5491
11000	1893	3.30	6516
12000	2065	3.60	7619
13000	2237	3.90	8801
14000	2409	4.20	10058

**25 x 3.5
DN 18**

Q	m	v	R
W	kg/h	m/s	Pa/m
1000	172	0.19	33
2000	344	0.38	109
3000	516	0.58	223
4000	688	0.77	369
5000	860	0.96	548
6000	1033	1.15	757
7000	1205	1.34	996
8000	1377	1.54	1264
9000	1549	1.73	1559
10000	1721	1.92	1882
11000	1893	2.11	2232
12000	2065	2.31	2609
13000	2237	2.50	3012
15000	2581	2.88	3895
17000	2925	3.27	4878
19000	3270	3.65	5961
21000	3614	4.03	7141

Q	32 x 4.4 DN 23			40 x 4.0 DN 32		50 x 4.5 DN 41	
	m	v	R	v	R	v	R
W	kg/h	m/s	mbar/m	m/s	mbar/m	m/s	mbar/m
1000	172	0.12	10	0.06	2	0.04	1
2000	344	0.23	33	0.12	7	0.07	2
3000	516	0.35	67	0.18	15	0.11	4
4000	688	0.46	110	0.24	24	0.15	7
5000	860	0.58	163	0.30	35	0.19	11
6000	1033	0.69	225	0.36	49	0.22	15
7000	1205	0.81	296	0.43	64	0.26	20
8000	1377	0.93	375	0.49	81	0.30	25
9000	1549	1.04	463	0.55	100	0.33	31
10000	1721	1.16	558	0.61	120	0.37	37
11000	1893	1.27	662	0.67	142	0.41	44
12000	2065	1.39	773	0.73	166	0.44	51
13000	2237	1.50	892	0.79	191	0.48	59
15000	2581	1.73	1151.9	0.91	247	0.56	76
17000	2925	1.97	1442	1.03	309	0.63	94
19000	3270	2.20	1760	1.15	376	0.70	115
21000	3614	2.43	2107	1.28	450	0.78	137
23000	3958	2.66	2482	1.40	530	0.85	162
25000	4302	2.89	2884	1.52	615	0.93	188
28000	4818	3.24	3539	1.70	754	1.04	230
31000	5335	3.59	4253	1.88	906	1.15	276
35000	6023	4.05	5297	2.13	1127	1.30	343
40000	6883			2.43	1434	1.48	436
45000	7744			2.74	1774	1.67	539
50000	8604			3.04	2146	1.85	651
60000	10325			3.65	2985	2.22	905
70000	12046			4.26	3949	2.59	1196
80000	13767					2.96	1523
90000	15488					3.33	1886
100000	17208					3.70	2284
110000	18929					4.07	2716

MAINPEX pipe friction resistance depending on Q and a spread of 10k (45°C / 55°C)

16 x 2.2 0.106 l/m				20 x 2.8 0.163 l/m				25 x 3.5 0.254 l/m			
Q	m	v	R	Q	m	v	R	Q	m	v	R
W	kg/h	m/s	Pa/m	W	kg/h	m/s	Pa/m	W	kg/h	m/s	Pa/m
400	34	0.09	10	1000	86	0.15	30.1	1000	86	0.10	10
600	52	0.14	33	2000	172	0.30	98.7	2000	172	0.19	33
800	69	0.18	54	3000	258	0.45	199.4	3000	258	0.29	66
1000	86	0.23	79	4000	344	0.60	329.4	4000	344	0.38	109
1200	103	0.28	109	5000	430	0.75	487	5000	430	0.48	162
1400	120	0.32	142	6000	516	0.90	671	6000	516	0.58	223
1600	138	0.37	178	7000	602	1.05	880.5	7000	602	0.67	292
1800	155	0.41	219	8000	688	1.20	1114.7	8000	688	0.77	369
2000	172	0.46	263	9000	774	1.35	1373	9000	774	0.86	455
2200	189	0.51	310	10000	860	1.50	1654.9	10000	860	0.96	548
2400	207	0.55	361	11000	946	1.65	1959.9	11000	946	1.06	649
2600	224	0.60	415	12000	1033	1.80	2287.7	12000	1033	1.15	757
2800	241	0.64	472	13000	1119	1.95	2637.9	13000	1119	1.25	873
3000	258	0.69	533	14000	1205	2.10	3010.2	15000	1291	1.44	1126
3200	275	0.74	597					17000	1463	1.63	1408
3400	293	0.78	664					19000	1635	1.83	1717
3600	310	0.83	734					21000	1807	2.02	2054
3800	327	0.87	807								
4000	344	0.92	883								
4200	361	0.97	963								
4400	379	1.01	1045								
4600	396	1.06	1130								
4800	413	1.10	1218								
5000	430	1.15	1309								
5400	465	1.24	1500								
5800	499	1.33	1702								
6200	533	1.43	1915								
6800	585	1.56	2256								
7400	637	1.70	2621								
8000	688	1.84	3011								
8800	757	2.02	3568								

Q	32 x 4.4 DN 25			40 x 4.0 DN 32		50 x 4.5 DN 40	
	m	v	R	v	R	v	R
W	kg/h	m/s	Pa/m	m/s	Pa/m	m/s	Pa/m
1000	86	0.06	3	0.03	0.4	0.02	0.2
2000	172	0.12	10	0.06	2.2	0.04	0.7
3000	258	0.17	20	0.09	4.4	0.06	1.4
4000	344	0.23	33	0.12	7.2	0.07	2.2
5000	430	0.29	48	0.15	10.5	0.09	3.3
6000	516	0.35	67	0.18	14.5	0.11	4.5
7000	602	0.40	87	0.21	18.9	0.13	5.8
8000	688	0.46	110	0.24	23.9	0.15	7.4
9000	774	0.52	136	0.27	29.4	0.17	9.1
10000	860	0.58	163	0.30	35.3	0.19	10.9
11000	946	0.64	193	0.33	41.8	0.20	12.9
12000	1033	0.69	225	0.36	48.7	0.22	15.0
13000	1119	0.75	260	0.40	56.0	0.24	17.2
15000	1291	0.87	335	0.46	72.1	0.28	22.2
17000	1463	0.98	418	0.52	90.0	0.31	27.6
19000	1635	1.10	510	0.58	109.6	0.35	33.6
21000	1807	1.21	609	0.64	130.9	0.39	40.1
23000	1979	1.33	716	0.70	153.8	0.43	47.1
25000	2151	1.45	831	0.76	178.4	0.46	54.6
28000	2409	1.62	1018	0.85	218.3	0.52	66.8
31000	2667	1.79	1222	0.94	261.7	0.57	80.0
35000	3011	2.02	1519	1.06	325.0	0.65	99.3
40000	3442			1.22	412.6	0.74	125.9
45000	3872			1.37	509.5	0.83	155.4
50000	4302			1.52	615.4	0.93	187.6
60000	5163			1.82	853.9	1.11	260.0
70000	6023			2.13	1127.0	1.30	342.8
80000	6883					1.48	435.7
90000	7744					1.67	538.6
100000	8604					1.85	651.2
110000	9465					2.04	773.4

MAINPEX pipe friction resistance depending on Q and a spread of 15k (70°C / 50°C)

16 x 2.2
0.106 l/m

Q	m	v	R
W	kg/h	m/s	Pa/m
200	11	0.03	1
300	17	0.05	2
400	23	0.06	3
500	29	0.08	5
600	34	0.09	7
700	40	0.11	9
800	46	0.12	12
900	51	0.14	15
1000	57	0.15	19
1100	63	0.17	23
1200	69	0.18	27
1300	74	0.20	32
1400	80	0.21	37
1500	86	0.23	42
1600	91	0.24	48
1700	97	0.26	55
1800	103	0.27	61
1900	109	0.29	68
2000	114	0.30	75
2100	120	0.32	83
2200	126	0.33	91
2300	131	0.35	100
2400	137	0.36	109
2500	143	0.38	118
2600	149	0.39	127
2700	154	0.41	137
2800	160	0.42	148
2900	166	0.44	159
3000	171	0.45	170
3200	183	0.48	193
3400	194	0.51	218
3600	206	0.54	244
3800	217	0.57	272

20 x 2.8
0.163 l/m

Q	m	v	R
W	kg/h	m/s	Pa/m
500	29	0.05	2
1000	57	0.10	6
1500	86	0.15	14
2000	114	0.19	25
2500	143	0.24	39
3000	171	0.29	55
3500	200	0.34	76
4000	229	0.39	99
4500	257	0.44	125
5000	286	0.49	154
5500	314	0.54	186
6000	343	0.58	222
6500	371	0.63	260
7000	400	0.68	302
7500	429	0.73	347
8000	457	0.78	395

32 x 4.4
0.423 l/m

Q	m	v	R
W	kg/h	m/s	Pa/m
500	29	0.02	0.131
1000	57	0.04	1
1500	86	0.06	1
2000	114	0.08	2
2500	143	0.09	3
3000	171	0.11	5
3500	200	0.13	6
4000	229	0.15	8
4500	257	0.17	11
5000	286	0.19	13
5500	314	0.21	16
6000	343	0.23	19
6500	371	0.24	22
7000	400	0.26	26
7500	429	0.28	30
8000	457	0.30	34
8500	486	0.32	38
9000	514	0.34	43
9500	543	0.36	47
10000	571	0.38	52
10500	600	0.39	58
11000	629	0.41	63
11500	657	0.43	69
12000	686	0.45	76
12500	714	0.47	82
13000	743	0.49	89
13500	771	0.51	96
14000	800	0.53	103
14500	829	0.54	110
15000	857	0.56	118
16000	914	0.60	134
17000	971	0.64	152
18000	1029	0.68	170
19000	1086	0.71	189
20000	1143	0.75	210
21000	1200	0.79	231
22000	1257	0.83	254
23000	1314	0.86	278
24000	1371	0.90	302
25000	1429	0.94	328
26000	1486	0.98	355
27000	1543	1.01	383
28000	1600	1.05	411
29000	1657	1.09	441
30000	1714	1.13	472
31000	1771	1.16	504
32000	1829	1.20	537
33000	1886	1.24	571
34000	1943	1.28	607
35000	2000	1.31	643

40 x 4
0.804 l/m

Q	m	v	R
W	kg/h	m/s	Pa/m
2000	114	0.04	0.399
4000	229	0.08	2
6000	343	0.12	4
8000	457	0.16	6
10000	571	0.20	10
12000	686	0.24	14
14000	800	0.28	20
16000	914	0.32	26
18000	1029	0.36	32
20000	1143	0.39	40
22000	1257	0.43	48
24000	1371	0.47	57
26000	1486	0.51	67
28000	1600	0.55	78
30000	1714	0.59	90
32000	1829	0.63	102
34000	1943	0.67	115
36000	2057	0.71	129
38000	2171	0.75	144
40000	2286	0.79	160
42000	2400	0.83	176
44000	2514	0.87	193
46000	2629	0.91	211
48000	2743	0.95	230
50000	2857	0.99	250

MAINPEX pipe friction resistance depending on Q and a spread of 20k (70°C / 50°C)

16 x 2.2 0.106 l/m				20 x 2.8 0.163 l/m				25 x 3.5 0.254 l/m			
Q	m	v	R	Q	m	v	R	Q	m	v	R
W	kg/h	m/s	Pa/m	W	kg/h	m/s	Pa/m	W	kg/h	m/s	Pa/m
400	17	0.05	5	1000	43	0.07	5	1000	43	0.05	2
600	26	0.07	8	2000	86	0.15	29	2000	86	0.10	10
800	34	0.09	10	3000	129	0.22	57	3000	129	0.14	20
1000	43	0.12	24	4000	172	0.46	262	4000	172	0.19	33
1200	52	0.14	33	5000	215	0.37	139	5000	215	0.24	48
1400	60	0.16	43	6000	258	0.45	190	6000	258	0.29	66
1600	69	0.18	54	7000	301	0.52	249	7000	301	0.34	86
1800	77	0.21	66	8000	344	0.60	315	8000	344	0.38	109
2000	86	0.23	79	9000	387	0.67	387	9000	387	0.43	134
2200	95	0.25	93	10000	430	0.75	466	10000	430	0.48	161
2400	103	0.28	108	11000	473	0.82	551	11000	473	0.53	191
2600	112	0.30	124	12000	516	0.90	643	12000	516	0.58	222
2800	120	0.32	141	13000	558	0.97	740	13000	558	0.62	256
3000	129	0.35	159	14000	601	1.05	844	15000	644	0.72	329
3200	137	0.37	178					17000	730	0.82	410
3400	146	0.39	198					19000	816	0.91	499
3600	155	0.42	218					21000	902	1.01	596
3800	163	0.44	240								
4000	172	0.46	262								
4200	180	0.49	285								
4400	189	0.51	309								
4600	198	0.53	334								
4800	206	0.55	360								
5000	215	0.58	387								
5400	232	0.62	442								
5800	249	0.67	501								
6200	266	0.72	563								
6800	292	0.79	662								
7400	318	0.85	768								
8000	344	0.92	881								
8800	378	1.02	1042								

Q	32 x 4.0 DN 25			40 x 4.0 DN 32		50 x 4.5 DN 40	
	m	v	R	v	R	v	R
W	kg/h	m/s	Pa/m	m/s	Pa/m	m/s	Pa/m
1000	43	0.03	0.8	0.02	0.2	0.01	0.1
2000	86	0.06	3.0	0.03	0.4	0.02	0.2
3000	129	0.09	6.0	0.05	1.3	0.03	0.4
4000	172	0.12	9.9	0.06	2.2	0.04	0.7
5000	215	0.14	14.5	0.08	3.2	0.05	1.0
6000	258	0.17	19.9	0.09	4.4	0.06	1.4
7000	301	0.20	25.9	0.11	5.7	0.06	1.8
8000	344	0.23	32.7	0.12	7.1	0.07	2.2
9000	387	0.26	40.2	0.14	8.8	0.08	2.7
10000	430	0.29	48.3	0.15	10.5	0.09	3.3
11000	473	0.32	57.0	0.17	12.4	0.10	3.8
12000	516	0.35	66.4	0.18	14.4	0.11	4.5
13000	558	0.38	76.4	0.20	16.6	0.12	5.1
15000	644	0.43	98.2	0.23	21.3	0.14	6.6
17000	730	0.49	122.3	0.26	26.5	0.16	8.17
19000	816	0.55	148.8	0.29	32.2	0.18	9.9
21000	902	0.61	177.6	0.32	38.4	0.19	11.8
23000	988	0.66	208.5	0.35	45.0	0.21	13.9
25000	1074	0.72	241.7	0.38	52.2	0.23	16.0
28000	1203	0.81	295.4	0.42	63.7	0.26	19.6
31000	1332	0.89	353.9	0.47	76.2	0.29	23.4
35000	1504	1.01	439.1	0.53	94.5	0.32	29.0
40000	1718			0.61	119.7	0.37	36.7
45000	1933			0.68	147.6	0.42	45.2
50000	2148			0.76	177.9	0.46	54.5
60000	2578			0.91	246.2	0.55	75.3
70000	3007			1.06	324.2	0.65	99.0
80000	3437					0.74	125.6
90000	3866					0.83	155.0
100000	4296					0.92	187.1
110000	4726					1.02	221.9

7. Standards

The applicable standards and directives for the heating and sanitary installation are shown in the following table. Only the most important reference DIN standards, requirements, regulations and ordinances are listed:

Standards and directives	Meaning
DIN 1988-100	Technical regulations for drinking water installations, protection of the drinking water, maintenance of the drinking water quality - DVGW Technical Regulations
DIN 1988-200	Technical regulations for drinking water installations, installation type A (closed systems), planning, components, devices, materials - DVGW Technical Regulations
DIN 1988-300	Regulations for drinking water installations, determination of pipe diameter, DVGW Technical Regulations
DIN 1988-600	Technical regulations for drinking water installations (TRWI) Part 6: Fire extinguishing and fire protection systems - DVGW Technical Regulations
DIN 2000	Central drinking water supply - guidelines for arrangements for drinking water, planning, construction, operation and maintenance of the supply systems - DVGW Technical Regulations
DIN 4703	Radiators
DIN 4721	Plastic pipeline systems for hot water underfloor heating and radiator connection - polyethylene of raised temperature resistance
DIN 4725-200	Hot water underfloor heating systems and components - Part 200: Provisions of the heat output (pipe covering < greater > 0.065m)
DIN EN 806-1	Technical regulations for drinking water installations - Part 1: General; German version EN 806-1:2001 + A1:2001
DIN EN 806-2	Technical regulations for drinking water installations - Part 2 Planning; German version EN 806-2:2005
DIN EN 12828	Heating systems in buildings - planning of hot water heating systems; German version EN 12828:2003
DIN EN 14336	Heating systems in buildings - installation and approval of hot water heating systems; German version EN 14336:2004
DIN 4726	Hot water surface heating systems and radiator connections - plastic pipeline and multi-layer pipeline systems
DIN EN 12831	Heating systems in buildings - method for calculating the standard heating load
DIN EN 1264	Room surface-integrated heating and cooling systems with water flow
DIN 18560	Floor screeds in building construction
DIN 30660	Sealants for the gas and water supply as well as for water heating systems - non-hardening sealants and polytetrafluoroethylene (PTFE- bands for metallic thread connections of domestic installation)
DIN 18380	VOB Construction Tendering and Contract Regulation - Part C: General technical contractual obligations for construction work (ATV) - heating systems and central water heating systems
DIN EN 12170	Heating systems in buildings - maintenance and operating manuals - heating systems which require qualified operating personnel
VDI/DVGW 6023	Hygiene in drinking water installations; Requirements for planning, execution, operation and maintenance

8. Certificates and guarantees



CERTIFICATE

Extended Warranty

We herewith confirm the extension of the warranty for DVGW certified components (pipe and fittings) for the MAINPEX SLIDING SLEEVE SYSTEM (DW-8501BS0475) AND MAINPRESS SYSTEM (DW-8501BU0326).

For a period of **10 years**, we will provide replacement for:

- 1) MAINCOR pipe systems MAINPEX (MPX), MAINPRESS (MPR) and MAINPIPE in the event of damage that is demonstrably due to defects in production or material, as far as the manufacturer is held responsible.
- 2) Damage that is caused by production defects to the property of third parties and any resulting consequential losses.
- 3) Expenses of third parties caused by removing, dismounting, disassembly and clearing of defective products as well as for mounting and laying non-defective products to be supplied by us.

The warranty extends to all above mentioned system components such as pipes and fittings insofar as supplied by us. No warranty is granted for laying and installation errors. The technical documentation and application guidelines shall be decisive.

For coverage, there is an extended product liability insurance with a renowned German insurance company with the following sums insured:

- 3.000.000,- EUR lump-sum, for bodily injury as well as economic losses of property and product
- 2.000.000,- EUR maximum sum for an individual person

Schweinfurt, December 1, 2025



Dieter Pfister
Managing director



Österreichische Vereinigung für das Gas- und Wasserfach
A-1010 Wien, Schuberting 14
Telefon: +43 / 1 / 513 15 88-0* / Telefax: +43 / 1 / 513 15 88-25
E-Mail: office@ovgw.at / Internet: www.ovgw.at
Akkreditiert durch das Bundesministerium
für Arbeit und Wirtschaft



ÖVGW-Zertifikat

Über die Verleihung des Rechtes
zur Führung der ÖVGW-Qualitätsmarke Wasser

Registrierungsnummer

W 1.471

Geltungsdauer

bis Ende Oktober 2026

Inhaber

Maincor Rohrsysteme GmbH & Co. KG
Silbersteinstraße 14
97424 Schweinfurt
DEUTSCHLAND

◆ Vertrieb in Österreich

Maincor Gebäudetechnik
Bachwinkel 27
5761 Maria Alm

Hersteller

- System und Verbinder:
Maincor Rohrsysteme GmbH & Co. KG / DE
- Rohre:
Gerodur MPM Kunststoffverarbeitung GmbH &
Co KG / DE
Becker Plastics GmbH / DE

Prüfungsart

Verlängerungsprüfung

Prüfbericht

TGM – VA KU 30061/1 vom 9. Oktober 2023

Qualitätsstandards/Prüfrichtlinien

- QS-W 301 Ausgabe Mai 2020
- QS-W 100 Ausgabe November 2022

Produkt

Mehrschichtverbund-Rohre M mit weißem
Außenmantel

MPX MAINPEX

PE-RT Typ II / AI / PE-RT Typ II

in den Dimensionen
(16x2,2), (20x2,8), (25x3,5), (32x4,4), (40x4,0)
und (50x4,5) mm

Anwendungsklassen 1, 2, 4 / $p_D = 10$ bar und
Anwendungsklasse 5 / $p_D = 8$ bar

Weitere Angaben siehe Seite 2

Die Verleihung erfolgt unter Zugrundelegung der Allgemeinen Geschäftsbedingungen GW 30 ÖVGW-Qualitätsmarke
Produkte Gas & Wasser „Voraussetzungen für die Zuerkennung der ÖVGW-Qualitätsmarke für Produkte der Gas- und
Wasserversorgung.“

Wien, am 24. November 2023

Dipl.-Ing. (FH) Alexander Schwanzler
Leiter der ÖVGW-Zertifizierungsstelle

ZVR 818158001



CERT

DVGW-Baumusterprüfzertifikat

DVGW type examination certificate

DW-8501BS0475

Registriernummer
registration number

Anwendungsbereich <i>field of application</i>	Produkte der Wasserversorgung <i>products of water supply</i>
Zertifikatinhaber <i>owner of certificate</i>	Maincor Rohrsysteme GmbH & Co. KG Silbersteinstraße 14, D-97424 Schweinfurt
Vertreiber <i>distributor</i>	Maincor Rohrsysteme GmbH & Co. KG Silbersteinstraße 14, D-97424 Schweinfurt
Produktart <i>product category</i>	Installationssysteme und Systemverbinder (PN 10): Trinkwasserinstallationssystem (8501)
Produktbezeichnung <i>product description</i>	Trinkwasserinstallationssystem bestehend aus Verbundrohr PE-RT/AL/PE-RT und Schiebbehülsenverbindern, Typ M-MV, aus Messing verzinkt
Modell <i>model</i>	MPX MAINPEX
Prüfberichte <i>test reports</i>	Kontrollprüfung Labor: RA5832.221804.22 vom 14.02.2022 (SKH) Mechanikprüfung: B463/11 vom 08.12.2011 (IMA) Mechanikprüfung: 84786/08-I vom 15.09.2009 (IMA) Mechanikprüfung: B098/10 vom 06.08.2010 (IMA)
Prüfgrundlagen <i>test basis</i>	DVGW W 534-(P) (01.07.2015) DVGW CERT ZP 8500 (01.01.2017) UBA BWGL-Metalle (11.01.2023) UBA KTW-BWGL (07.03.2022) DVGW W 270 (01.11.2007)
Ablaufdatum / AZ <i>date of expiry / file no.</i>	10.12.2027 / 23-0011-WNV

25.01.2023 LE A-1/2

Datum, Bearbeiter, Blatt, Leiter der Zertifizierungsstelle
date, issued by, sheet, head of certification body



DVGW CERT GmbH
Zertifizierungsstelle

Josef-Wirmer-Str. 1-3
53123 Bonn

Tel. +49 228 91 88 - 888
Fax +49 228 91 88 - 993

www.dvgw-cert.com
info@dvgw-cert.com



GERMANY

Hotline: +49 9721 659 77-100

Fax: +49 9721 659 77-200

Homepage: www.maincor.de

E-Mail: info@maincor.de

MAINCOR Rohrsysteme GmbH & Co. KG

Silbersteinstraße 14

97424 Schweinfurt



www.maincor.de



info@maincor.de



[MaincorRohrsysteme](#)